

PreciseFlexTM 400 Robots

Service Manual

Part Number 628700, Revision A



Brooks Automation

Information provided within this document is subject to change without notice, and although believed to be accurate, Brooks Automation assumes no responsibility for any errors, omissions, or inaccuracies.

AcuLigner™, Advan Tag™, AutoTeach™, ATR™, AXM™, BiSymmetrik™, CenterSmart™, Crate to Operate™, CrossingConnect™, DARTS™, Enerta™, e-RMA™, e-Spares™, e-Volution™, Falcon™, FIXLOAD™, FrogLeg™, GuardianPro™, Independent Twin Linear Exchange™, InCooler™, InLigner™, Isoport™, ITLX™, Jet™, Jet Engine™, LEAP™, LeapFrog™, LowProfile™, LPT™, M2 Nano™, Marathon 2, Marathon Express, PASIV™, Pathway™, PowerPak™, PowerTools™, PuroMaxx™, QuadraFly™, Radius™, Radiant™, Radiant Express™, Reliance™, Reliance ATR™, RetroEase™, SCARA™, SmartPM™, SMIF-INX™, SMIF-LPT™, SPOTLevel™, The New Pathway to Productivity™, Time Optimized Trajectory™, Time Optimal Trajectory™, Time Optimized Path™, TopCooler™, TopLigner™, VacuTran™, VersaPort™, WaferEngine™, LEAP™, Pathway™, GIO, GSB, Guidance 6600, Guidance 6430, Guidance 6420, Guidance 6410, Guidance 6000, Guidance 3400, Guidance 3300, Guidance 3200, Guidance 2600, Guidance 2400, Guidance 2300, Guidance 2200, Guidance 1400, Guidance 1300, Guidance 1200, Guidance 0200 Slave Amplifier, Guidance 0006, Guidance 0004, Guidance Controller, Guidance Development Environment, GDE, Guidance Development Suite, GDS, Guidance Dispense, Guidance Input and Output Module, Guidance Programming Language, GPL, Guidance Slave Board, Guidance System, Guidance System D4/D6, PreciseFlex™ 300, PreciseFlex™ 400, PreciseFlex™ 3400, PreciseFlex™ 1300, PreciseFlex™ 1400, PreciseFlex™ DD4, PreciseFlex™ DD6, PreciseFlex™ DDR, PreciseFlex™ G5400, PreciseFlex™ G5600, PreciseFlex™ G6400, PreciseFlex™ G6410, PreciseFlex™ G6420, PreciseFlex™ G6430, PreciseFlex™ G6600, PreciseFlex™ GSBP Slave Amp, PreciseFlex™ PFD0, PrecisePlace 100, PrecisePlace 0120, PrecisePlace 0130, PrecisePlace 0140, PrecisePlace 1300, PrecisePlace 1400, PrecisePlace 2300, PrecisePlace 2400, PrecisePower 300, PrecisePower 500, PrecisePower 1000, PrecisePower 2000, PreciseVision, and RIO logos are trademarks of Brooks Automation.

Fusion®, Guardian®, MagnaTran®, Marathon®, Razor®, Spartan®, Vision®, Zaris®, and the Brooks and design logo are registered U.S. trademarks of Brooks Automation.

All other trademarks are properties of their respective owners.

© 2024 Brooks Automation. All rights reserved. The information included in this manual is proprietary information of Brooks Automation, and is provided for the use of Brooks customers only and cannot be used for distribution, reproduction, or sale without the express written permission of Brooks Automation.

This technology is subject to United States export Administration Regulations and authorized to the destination only; diversion contrary to U.S. law is prohibited.

<p>Brooks Automation 15 Elizabeth Drive Chelmsford, MA 01824-2400 Tel: +1 978-262-2400 Fax: +1 978-262-2500</p>	<p>Brooks Automation, PreciseFlex Collaborative Robots 201 Lindbergh Avenue Livermore, CA 94551 Tel: +1-408-224-2838</p>
---	---



Worldwide Headquarters

15 Elizabeth Drive
Chelmsford, MA 01824 U.S.A.

Brooks Automation, PreciseFlex Collaborative Robots

201 Lindbergh Avenue
Livermore, CA 94551 U.S.A

Technical Support

Location	Contact	Website
North America	+1-800-447-5007 (Toll-Free) +1-978-262-2900 (Local) +1-408-224-2838 (PreciseFlex™)	http://www.brooks.com/
Europe	support_preciseflex@brooksautomation.com	
Japan	+81 120-255-390 (Toll Free) +81 45-330-9005 (Local)	
China	+86 21-5131-7066	
Taiwan	+886 080-003-5556 (Toll Free) +886 3-5525258 (Local)	
Korea	1800-5116 (Toll Free)	
Singapore	+65 1-800-4-276657 (Toll Free) +65 6309 0701 (Local)	

General Emails

Division	Email Address
Sales	sales_preciseflex@brooksautomation.com
Technical Support	support_preciseflex@brooksautomation.com
Technical Publications	Technical.Publications@brooksautomation.com

**Brooks Automation**

15 Elizabeth Drive
Chelmsford, MA
01824-2400
Tel: +1 978-262-2400
Fax: +1 978-262-2500
www.brooks.com

Brooks Locations Worldwide:

Brooks Automation

46702 Bayside Parkway
Fremont, CA 94538
Tel: +1-510-661-5000
Fax: +1-510-661-5166

Brooks Automation

AIM Servicios Administrativos
S de RL de CV
Carretera Huinalá km 2.8
Parque Industrial Las Américas
66640 Apodaca, NL Mexico
Tel: +52 81 8863-6363

Brooks Automation (Germany) GmbH

Ernst-Ruska-Ring 11
07745 Jena, Germany
Tel: +49 3641 4821 100
Fax: +49 3641 4821 4100

Brooks Automation (Germany) GmbH

Daimler-Straße 7
78256 Steißlingen, Germany
Tel: +49-7732-9409-0
Fax: +49-7732-9409-200

Brooks Automation

9601 Dessau Road, Suite 301
Austin, TX 78754
Tel: +1 512-912-2840
Toll-Free: +1 800-367-4887

Brooks Automation (Israel) Ltd.

Mevo Yerach 5
Kiryat-Gat 82000
Israel
Tel: +972 8672 2988
Fax: +972 8672 2966

Brooks Technology (Shanghai) Limited

2nd Floor, No. 72,
887 Zuchongzhi Road
Zhangjiang Hi-Tech
Park Pudong, Shanghai
China 201203
Tel: +86-21-5131-7070
Fax: +86-21-5131-7068

Brooks Japan K.K.

HEADQUARTERS
Nisso Bldg. No 16, 9F
3-8-8 ShinYokohama, Kohoku-ku
Yokohama, Kanagawa 222-0033
Tel: +81-45-477-5570
Fax: +81-45-477-5571

Brooks Japan K.K.

YOKOHAMA TECHNICAL
CENTER
852-1 Kawamuko-cho, Tsuzuki-ku
Yokohama, Kanagawa 224-0044
Tel: +81-45-477-5250
Fax: +81-45-470-6800

Brooks Japan K.K.

KUMAMOTO SERVICE OFFICE
202 Mirai Office II
312-1 Tatsudamachi Yuge
Tatsuda, Kumamoto 861-8002
Tel: +81-96-327-9720
Fax: +81-96-327-9721

Brooks CCS Japan K.K.

CONTAMINATION CONTROL
SOLUTIONS
Nisso Bldg. No 16, 9F
3-8-8 ShinYokohama, Kohoku-ku
Yokohama, Kanagawa 222-0033
Tel: +81-45-477-5570
Fax: +81-45-477-5571

Brooks Automation Ltd.

TAIWANHEADQUARTERS
5F-5, No.32, Tai-Yuen Street
Chu-Pei City
Hsinchu County 302, Taiwan,
R.O.C.
Tel: +886-3-552 5258
Fax (G&A): +886-3-552 5255
Fax (Sales): +886-3-552 5200

Brooks Automation Korea, Inc.

#35 Giheungdanji-Ro 121Beon-
Gil
Giheung-Gu, Yongin-Si
Gyeonggi-Do, 17086
Korea
Tel: +82-31-288-2500
Fax: +82-31-287-2111

Brooks Automation CCS RS AG

Lohstampfstrasse 11
CH-8274 Tagerwilen, Switzerland
Tel: + 41 71-666-72-10
Fax: + 41 71-666-72-11

Brooks Automation Korea

#35 Giheungdanji-Ro 121Beon-
Gil
Giheung-Gu, Yongin-Si
Gyeonggi-Do, 17086
Korea
Tel: +82-31-288-2500
Fax: +82-31-287-2111

Brooks Automation (S) Pte Ltd

51-18-C1 Menara BHL,
57 Jalan Ahmad Shah,
10050, Penang,
Malaysia
Tel: +60 4 3701012
Fax: +60 4 3701015

Brooks Automation (Singapore) Pte Ltd

Blk 5008 Ang Mo Kio Avenue 5
#05-08, Techplace II
Singapore 569874
Tel: +65-6836-3168
Fax: +65-6836-3177

Brooks Automation Ltd.

TAINAN OFFICE
3F., No.11, Nanke 3rd Rd., Xinshi
Dist.
Tainan Science Park
Tainan City 74147, Taiwan
(R.O.C.)
TEL: +886-6-505-0268
FAX: +886-6-505-5228

Brooks Automation Precise Collaborative Robotics

201 Lindbergh Drive
Livermore, CA 94551
Tel: +1-978-262-2400

Revision History

Revision	ECO	Date	Action	Author
A	EC154084	April 19, 2024	Released manual at Rev. A to follow standard Brooks technical publication styles.	M. Ashenfelder

Table of Contents



1. Safety	1
Safety Setup	1
Authorized Personnel Only	1
Explanation of Hazards and Alerts	2
Safety Text	2
Safety Icons	2
Signal Words and Color	2
Alert Example	3
General Safety Considerations	4
Mechanical Hazards	6
Electrical Hazards	7
Ergonomic Hazards	8
Emergency Stop Circuit (E-Stop)	10
Recycling and Hazardous Materials	10
2. Service Procedures	11
Recommended Tools	11
Troubleshooting	11
Encoder Operation Error	13
Replacing the Encoder Battery	15
Calibrating the Robot: Setting the Encoder Zero Positions	16
Replacing Belts and Motors	20
General Belt Tensioning	20
Tensioning the J1 (Z Column) Belts	20
Tensioning the 1st Stage Belt	20
Tensioning the 2nd Stage Belt	21
Tensioning the J2 Belt	23
Tensioning the J3 Belt (Before 2014)	25
Tensioning the J4 Belt (Before 2014)	26
Tensioning the J3 and J4 Belts (2014)	27
Tensioning the Belt on the Optional Linear Axis	28
Replacing the Power Supplies, Energy Dump PCA, or J1 Stage Two (Output) Timing Belt	29
Replacing the Robot Controller	33
Replacing the Servo Gripper Controller	36
Replacing the Agilent Servo Gripper Finger Pads	38
Replacing the Gripper Spring or Cable	39
Adjusting the Gripper Backlash or Centering Fingers	40
Adjusting the Gripper Brake (for Grippers with Brake)	42
Replacing the Electric Grippers or Slip Ring Harness	43
Replacing the Linear Axis Controller	45
Installing the Optional GIO Board	47
Replacing the Main Harness	50
Replacing the Outer Link Harness	50
Replacing the Z-axis Motor Assembly	53

Replacing the J2 (Shoulder) Axis Motor or Timing Belt	56
Replacing the J3 (Elbow) Axis Motor or Timing Belt	60
Replacing the J4 (Wrist) Axis Motor or Timing Belt	63
Replacing Servo Gripper with Pneumatic or Vacuum Gripper	66
Appendices	77
Appendix A: Product Specifications	78
Appendix B: Environmental Specifications	80
Appendix C: Spare Parts List	81
Appendix D: Preventative Maintenance	83
Appendix E: Belt Tensions, Gates Tension Meter	85
Appendix F: Example Performance Level Evaluation	87
Example Workcell Description	87
Normal Operator Interaction with Robot	87
Possible Low Frequency (rare) Interaction with Robot	87
Appendix G: TUV Verification of PF400 Collision Forces	89
Appendix H: Table A2 from ISO/TS 15066: 2016, Biomechanical Limits	93
Appendix I: Safety Circuits for PF400 500gm Payload	95
Appendix J: Robot Anatomy	96
Appendix K: System Diagram and Power Supplies	99
Appendix L: Torque Values for Screws	117

1. Safety

Safety Setup

Brooks uses caution, warning, and danger labels to convey critical information required for the safe and proper operation of the hardware and software. Read and comply with all labels to prevent personal injury and damage to the equipment.

 DANGER Read the Safety Chapter	
<p>Failure to review the <i>Safety</i> chapter and follow the safety warnings can result in serious injury or death.</p> <ul style="list-style-type: none">• All personnel involved with the operation or maintenance of this product must read and understand the information in this safety chapter.• Follow all applicable safety codes of the facility as well as national and international safety codes.• Know the facility safety procedures, safety equipment, and contact information.• Read and understand each procedure before performing it.	

Authorized Personnel Only

This product is intended for use by trained and experienced personnel. Operators must comply with applicable organizational operating procedures, industry standards, and all local, regional, national, and international laws and regulations.

Explanation of Hazards and Alerts

This manual and this product use industry standard hazard alerts to notify the user of personal or equipment safety hazards. Hazard alerts contain safety text, icons, signal words, and colors.

Safety Text

Hazard alert text follows a standard, fixed-order, three-part format.





- Identify the hazard
- State the consequences if the hazard is not avoided
- State how to avoid the hazard.

Safety Icons

- Hazard alerts contain safety icons that graphically identify the hazard.
- The safety icons in this manual conform to ISO 3864 and ANSI Z535 standards.

Signal Words and Color

Signal words inform of the level of hazard.

	<p>Danger indicates a hazardous situation which, if not avoided, will result in serious injury or death.</p> <p>The Danger signal word is white on a red background with an exclamation point inside a yellow triangle with black border.</p>
	<p>Warning indicates a hazardous situation which, if not avoided, could result in serious injury or death.</p> <p>The Warning signal word is black on an orange background with an exclamation point inside a yellow triangle with black border.</p>
	<p>Caution indicates a hazardous situation or unsafe practice which, if not avoided, may result in minor or moderate personal injury.</p> <p>The Caution signal word is black on a yellow background with an exclamation point inside a yellow triangle with black border.</p>
	<p>Notice indicates a situation or unsafe practice which, if not avoided, may result in equipment damage.</p> <p>The Notice signal word is white on blue background with no icon.</p>



Alert Example

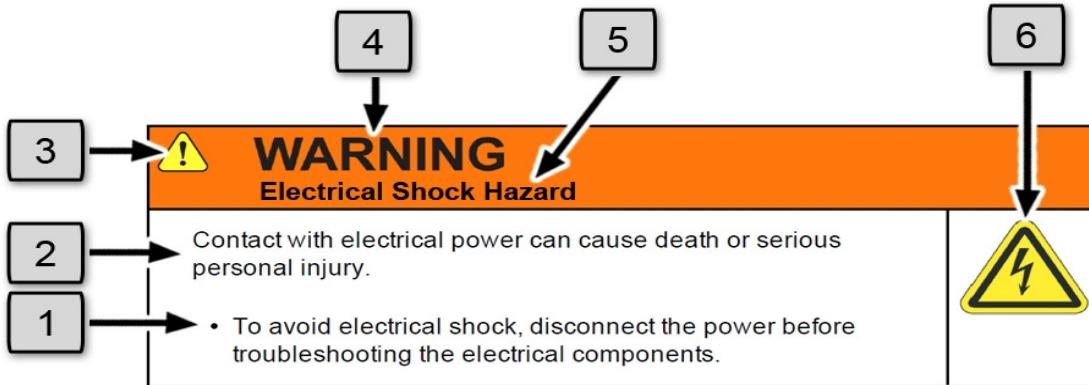

The following is an example of a Warning hazard alert.







Number	Description
1.	How to Avoid the Hazard
2.	Source of Hazard and Severity
3.	General Alert Icon
4.	Signal Word
5.	Type of Hazard
6.	Hazard Symbol(s)



General Safety Considerations



 WARNING Software	
<p>Software is not safety rated. Unplanned motion can occur as long as power is supplied to the motors. Maximum torque could be momentarily applied that may cause equipment damage or personal injury.</p> <ul style="list-style-type: none">• Only operate the robot with its covers installed.• Guarantee that safety controller features are in place (for example, an emergency stop button and protective stop).• Regularly test safety components to prove that they function correctly.	 



 WARNING Robot Mounting	
<p>Before applying power, the robot must be mounted on a rigid test stand, secure surface, or system application. Improperly mounted robots can cause excessive vibration and uncontrolled movement that may cause equipment damage or personal injury.</p> <ul style="list-style-type: none">• Always mount the robot on a secure test stand, surface, or system before applying power.	



 WARNING Do Not Use Unauthorized Parts	
<p>Using parts with different inertial properties with the same robot application can cause the robot's performance to decrease and potentially cause unplanned robot motion that could result in serious personal injury.</p> <ul style="list-style-type: none">• Do not use unauthorized parts.• Confirm that the correct robot application is being used.	

 WARNING Magnetic Field Hazard	
<p>This product contains magnetic motors that can be hazardous to implanted medical devices, such as pacemakers, and cause personal harm, severe injury, or death.</p> <ul style="list-style-type: none"> • Maintain a safe working distance of 30 cm from the motor when with an energized robot if you use a cardiac rhythm management device. 	



 CAUTION Unauthorized Service	
<p>Personal injury or damage to equipment may result if this product is operated or serviced by untrained or unauthorized personnel.</p> <ul style="list-style-type: none"> • Only qualified personnel who have received certified training and have the proper job qualifications are allowed to transport, assemble, operate, or maintain the product. 	

 CAUTION Damaged Components	
<p>The use of this product when components or cables appear to be damaged may cause equipment malfunction or personal injury.</p> <ul style="list-style-type: none"> • Do not use this product if components or cables appear to be damaged. • Place the product in a location where it will not get damaged. • Route cables and tubing so that they do not become damaged and do not present a personal safety hazard. 	



 CAUTION Inappropriate Use	
<p>Use of this product in a manner or for purposes other than for what it is intended may cause equipment damage or personal injury.</p> <ul style="list-style-type: none"> • Only use the product for its intended application. • Do not modify this product beyond its original design. • Always operate this product with the covers in place. 	

 CAUTION Seismic Restraint	
<p>The use of this product in an earthquake-prone environment may cause equipment damage or personal injury.</p> <ul style="list-style-type: none">The user is responsible for determining whether the product is used in an earthquake prone environment and installing the appropriate seismic restraints in accordance with local regulations.	

Mechanical Hazards

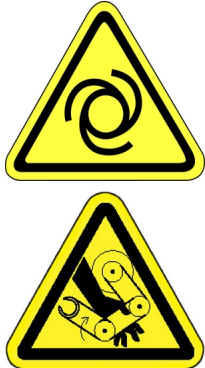

 CAUTION Pinch Point	
<p>Moving parts of the product may cause squeezing or compression of fingers or hands resulting in personal injury.</p> <ul style="list-style-type: none">Do not operate the product without the protective covers in place.	



 WARNING Automatic Movement	
<p>Whenever power is applied to the product, there is the potential for automatic or unplanned movement of the product or its components, which could result in personal injury.</p> <ul style="list-style-type: none">Follow safe practices for working with energized products per the facility requirements.Do not rely on the system software or process technology to prevent unexpected product motion.Do not operate the product without its protective covers in place.While the collaborative robotics system is designed to be safe around personnel, gravity and other factors may present hazards and should be considered.	



 CAUTION Vibration Hazard	
<p>As with any servo-based device, the robot can enter a vibratory state resulting in mechanical and audible hazards. Vibration indicates a serious problem. Immediately remove power.</p> <ul style="list-style-type: none"> • Before energizing, ensure the robot is bolted to a rigid metal chamber or stand. 	

Electrical Hazards

Refer to the specifications of the *Guidance Controller Quick Start Guide* for the electrical power.



 DANGER Electrical Shock Hazard	
<p>Contact with electrical power can cause personal harm and serious injury.</p> <ul style="list-style-type: none"> • To avoid electrical shock, disconnect the power before troubleshooting the electrical components. • Check the unit's specifications for the actual system power requirements and use appropriate precautions. • Never operate this product without its protection covers on. 	



 WARNING Electrical Burn	
<p>Improper electrical connection or connection to an improper electrical supply can result in electrical burns resulting in equipment damage, serious injury, or death.</p> <ul style="list-style-type: none"> • Always provide the robot with the proper power supply connectors and ground that are compliant with appropriate electrical codes. 	



 WARNING Electrical Fire Hazard	
<p>All energized electrical equipment poses the risk of fire, which may result in severe injury or death. Fires in wiring, fuse boxes, energized electrical equipment, computers, and other electrical sources require a Class C extinguisher.</p> <ul style="list-style-type: none">• Use a fire extinguisher designed for electrical fires (Class C in the US and Class E in Asia).• It is the facility's responsibility to determine if any other fire extinguishers are needed for the system that the robot is in.	

NOTICE	
<p>Improper handling of the power source or connecting devices may cause component damage or equipment fire.</p> <ul style="list-style-type: none">• Connect the system to an appropriate electrical supply.• Turn off the power before servicing the unit.• Turn off the power before disconnecting the cables.	

Ergonomic Hazards



 CAUTION Heavy Lift Hazard	
<p>Failure to take the proper precautions before moving the robot could result in back injury and muscle strain.</p> <ul style="list-style-type: none">• Use a lifting device and cart rated for the weight of the drive or arm.• Only persons certified in operating the lifting device should be moving the product.	

 CAUTION Tipover Hazard	
<p>This product has a high center of gravity which may cause the product to tip over and cause serious injury.</p> <ul style="list-style-type: none">• Always properly restrain the product when moving it.• Never operate the robot unless it is rigidly mounted.	

 CAUTION Trip Hazard	
<p>Cables for power and communication and facilities create trip hazards which may cause serious injury.</p> <ul style="list-style-type: none">• Always route the cables where they are not in the way of traffic.	

Emergency Stop Circuit (E-Stop)

The integrator of the robot must provide an emergency stop switch.

 WARNING Emergency Stop Circuit	
<p>Using this product without an emergency stop circuit may cause personal injury.</p> <ul style="list-style-type: none">• Customer is responsible for integrating an emergency stop circuit into their system.• Do not override or bypass the emergency stop circuit.	

Recycling and Hazardous Materials

Brooks Automation complies with the EU Directive 2002/96/EU Waste Electrical and Electronic Equipment (WEEE).

The end user must responsibly dispose of the product and its components when disposal is required. The initial cost of the equipment does not include cost for disposal. For further information and assistance in disposal, please email Brooks Automation Technical Support at support@preciseflex@brooksautomation.com.

2. Service Procedures

Recommended Tools

The following tools are recommended for these service procedures:

1. Gates Sonic Belt Tension Meter, Model 507C for checking timing belt tension.
2. A set of metric “stubby” hex L-keys, for example McMaster Carr PN 6112A21 with 1.5, 2.0, 2.5, 3.0, 4, 5, and 6 mm L Keys.
3. A set of metric hex drivers including 1.27, 1.5, 2.0, 2.5 and 3.0 mm driver, for example McMaster Carr PN 52975A21.
4. A pair of tweezers or needle nose pliers.
5. A pair of side angle cutters.
6. Small flat bladed screw driver, with 1.5 mm wide blade typical.
7. M5 socket driver or M5 open end wrench or pliers.

Troubleshooting

PreciseFlex robots and controllers have an extensive list of error messages. Refer to the *PreciseFlex Library* to search for a specific error message and cause. Listed in the table below are a few errors that may be generated by hardware failures.

Hardware Failure Errors

Symptom	Recommended Action
System error message generated	
“E-Stop not Enabled”	Check both Phoenix plug and 9 pin Dsub for E-Stop jumpers.

Symptom	Recommended Action
“Encoder Battery Low”	Replace absolute encoder battery in base of robot
“Encoder Battery Down”	If encoder cable has been disconnected, recalibrate robot. If battery voltage has dropped below 2.5V replace encoder battery and recalibrate robot.
“Encoder Operation Error”	Joint rotated too quickly with power off. See Procedure below.
“Encoder Data, Accel/decel Limit Error”	Check that the FPGA code is dated Jan 25, 2012 or later. Upgrade FPGA if necessary. Encoder cable may be damaged and encoder is getting intermittent communication, causing apparent jumps in position. Check encoder connectors on flat ribbon cable. Replace cable. Replace motor.
“Encoder Communication Error”	Check that the FPGA code is dated Jan 25, 2012 or later. Check encoder connectors on flat ribbon cable. Replace encoder cable or motor/encoder.
“Encoder quadrature error”	Replace slip ring. Replace motor/encoder (only Gripper motor).
“Missing zero index”	See “Encoder quadrature error”
“Motor duty cycle exceeded”	Reduce speed or acceleration of robot. Check for instability.
“Amplifier under voltage”	Motor power supply has reached current limit and shutdown. Slow down robot. Check Energy Dump PCA. Replace 48V supply.
“Amplifier Fault”	Check harness and motor for shorts.
“Amplifier Over Voltage”	Replace energy dump board. Check harness for shorts.
“Soft Envelope Error”	Make sure robot not pressing against surface. If this occurs on the gripper repeatedly, replace slip ring.
“Hard Envelope Error”	Typically means robot has crashed into something.
Pneumatic Gripper Sensor not working	Check continuity of cable through wrist. Check green lights on sensor to see if sensor is triggering.
“Time Out Nulling Error”	Check that joint is free to move with brake off. Check that joint is not vibrating or unstable. If unstable check belt tension. If Gripper, replace slip ring after checking that brake releases.
“Joint Out of Range”	The joint actual or commanded position may be beyond the software limit stop. Move joint back into range while monitoring virtual pendant or check program for commanded position.
“PAC Files Corrupted”	See recovering from corrupted PAC Files
Physical or audible problem	
Brown streaks on linear bearing	Clean with alcohol and add grease to bearing blocks. This should not be required sooner than 20,000 hours of run time. Grease is Alvania Grease EP2 from Shell.
Mechanical noise from any joint	Check joint bearings for failure. Re-tension belt.

Symptom	Recommended Action
Loud buzzing or vibration from any joint	Re-tension timing belts. If timing belt will not hold tension, replace.
Squeaking from Z belt	Apply thick grease to front and rear edges of belt, (Mobile 222 XP). Belt can get stiff over time and squeak against pulley flanges.

Encoder Operation Error

The PF400 robot is equipped with absolute encoders that keep track of the robot position even when AC power to the robot is disconnected. There is a battery in the base of the robot that provides standby power to the encoders. In standby mode, there is a limit on how quickly the motor can turn and still have the standby counter operate properly. The limits are 6,000 rpm and 4000 rad/s². Even at 100% speeds the robot joints normally do not move faster than about 2,000 rpm and 1300 rad/s². However, if the robot is shocked during shipping, it is possible the standby operation acceleration error limit may be exceeded. This can generate an encoder operation error that will prevent the robot from homing after power up.

This error will be displayed in the Operator Window of the Web Interface as “Encoder Operation Error” Robot 1: <axis number>.

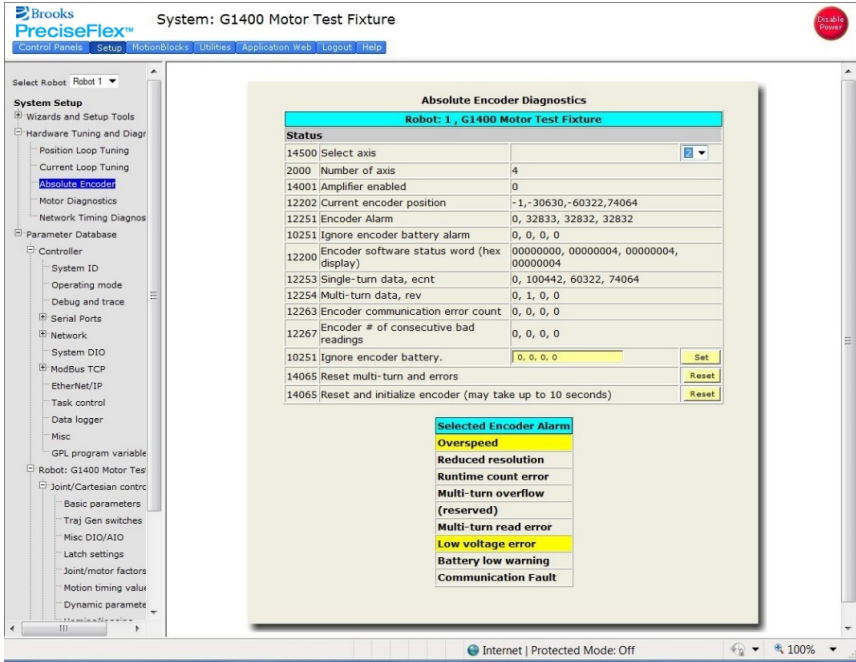

Assuming the robot has not been damaged by the shipping process, this error can be reset by the following procedure:

Step	Action
1.	Access the Web Operator Interface to the robot with either “Maintenance” or “Administrator” privileges.

Step	Action
<p>2.</p>	<p>In the Setup menu, select System Setup > Hardware Tuning and Diagnostics > Absolute Encoder.</p> 
<p>3.</p>	<p>In the drop-down menu at the top right of the screen, select the robot axis that was associated with the error and check to see if the Overspeed panel is yellow. This indicates an overspeed error during encoder standby mode due to shock or vibration. This error can be reset by selecting the reset button next to Reset and initialize encoder. This button resets error flags, but does not reset the encoder counters. The robot can then be homed normally.</p>
<p>4.</p>	<p>For cases where the encoder operation error was triggered by shipping vibration, IN MOST CASES the encoder will not have lost any position data. However after homing the robot it is a good idea to move the robot to the calibration position (using the calibration pins if desired-see Calibrating the Robot), or another known position, and check the joint angles in the Virtual Pendant in the Web Operator Interface. The joint angles in the Calibration Position are:</p> <ul style="list-style-type: none"> • Z-axis: -1 mm (-2 mm for Beta robots) • J2 or Shoulder: -90 • J3 or Elbow: 179.99 • J4 or Wrist: -180

If the robot joints after this procedure followed by homing are different from the above, then the robot needs to be re-calibrated. See [Replacing the Encoder Battery](#).

Replacing the Encoder Battery

 DANGER Electrical Shock	
Before replacing the encoder battery, the AC power should be disconnected. Removing the front cover allows access to the AC power terminals.	

The Encoder Battery is designed to last for several years with robot power turned off. With robot power turned on, there is no drain on the battery. The battery voltage is monitored by the system. The nominal battery voltage is 3.6 Volts. If the battery voltage drops to 3.3 Volts an error message “Encoder Battery Low” is generated. At this level the absolute encoder backup function will still work, however the Battery should be replaced. If the voltage drops to 2.5 Volts, an error message “Absolute Encoder Down” is generated. At this point, the absolute encoder backup function will not work.

If any motor/encoder is disconnected from the encoder battery by disconnecting the encoder cable, the “Encoder Battery Low” or Encoder Battery Down” message will be generated. However in this case the encoder battery does not need to be replaced. It is only necessary to re-calibrate the robot.

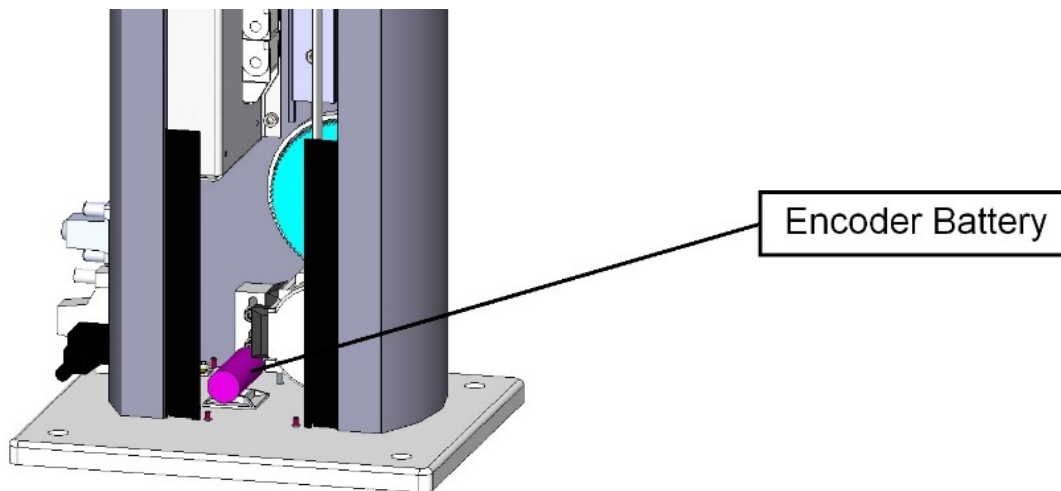
**Tools Required:**

- 3.0 mm hex driver or hex L wrench

Parts Required:

- New Encoder Battery (PF00-EA-00002)
- 6 in long by 1.25 wide tie wrap

To replace the Encoder Battery, perform the following procedure:

Step	Action
1.	Turn off power to the robot and remove the AC power plug.
2.	Remove the Top Plate of the robot by removing the (4) M5 low socket head screws from the top plate of the robot that attach the top plate to the Z column. Lift up the Top Plate.
3.	Remove the Front Cover by lifting it out vertically.
4.	The Encoder Battery is located in the base of the robot behind the Z Column Front Cover. Attach the new Encoder Battery to the hold down with a tie wrap.
5.	Replace the Front Cover and Top Plate.

If the error message “Encoder Battery Down” was generated, the robot must be re-calibrated after this procedure. Otherwise it is not necessary to re-calibrate the robot.

Calibrating the Robot: Setting the Encoder Zero Positions

Cal_PP is a service program that must be run to set the zero positions of the absolute encoders on each motor. The zero positions must be re-established if any of the motors are replaced, their cables disconnected for a long duration, or the encoder backup battery has been disconnected.

Cal_PP is supplied on the *Guidance Controller System Software CD*. To run Cal_PP, the controller must be configured to run GPL programs and Cal_PP must be loaded into the controller's memory (See [Appendix D: Preventative Maintenance](#)).

Tools Required:

- 2.5 mm and 3.0 mm hex drivers or hex L wrenches
- Set of (3) Calibration Dowel Pins, located in plastic bag inside the hollow slot in the front cover

The following procedure describes the steps for defining the zero positions of the PF400 robot axes using Cal_PP.

Step	Action
1.	Enable power to the robot's controller, but do not turn on power to the motors. (This procedure should be executed with the motor power off. The robot does not move).
2.	The CALPP program is typically installed at the factory and should be loaded into flash memory. Using the Web-based Operator Control Panel, first unload any currently loaded programs. Select the UnLoad item in the left scrolling window and click Perform Operation . This ensures that no GPL project is currently selected for execution.
3.	Select the Load item and click Perform Operation . This displays a pop-up list of Projects that are in the flash disk and available for execution.
4.	In the window, click CALPP_RevXX and click Select . To execute the Project, select Start application and click Perform Operation . If CALPP is not loaded in the robot, first Load Cal_PP into the controller's memory from a PC, using the web Operator Control Panel, as described in Software Reference .
5.	Manually move the robot into the configuration shown in Step 10. The top cover of the outer link will need to be removed by removing the (4) M3 X 20 SHCS that are located in counter bores under the outer link. <i>NOTE: If the optional Linear Axis is installed, move the Linear Axis carriage to the hard stop near the connector end cap. For the Linear Axis calibration, be sure to use CALPP Revision 21 or later.</i>
6.	Ensure that the Z-axis is resting on the lower hard stop by releasing the Z-axis brake by pushing on the brake release button under the shoulder while supporting the robot arm, and lowering the robot arm gently until it rests on the lower hard stop.
7.	If the Calibration Pins have not already been removed from the robot, it may be necessary to remove the top cover of the robot by removing the (4) M5 Low Head screws with a 3.0 mm hex driver and then removing the front cover to access the bag with the Calibration Pins which are inside the front cover extrusion at the bottom.
8.	Insert an M3 X 30 mm Calibration Dowel Pin into the J4 (wrist) pulley with the gripper positioned under the outer link and rotate the gripper back and forth until the pin drops into a slot in the outer link, locating the gripper under the center of the outer link.
9.	Insert a tapered 0.5 in Calibration Dowel Pin into the hole in the bottom of the shoulder. Rotate the inner link counter-clockwise until it rests against this pin as shown in Step 10.

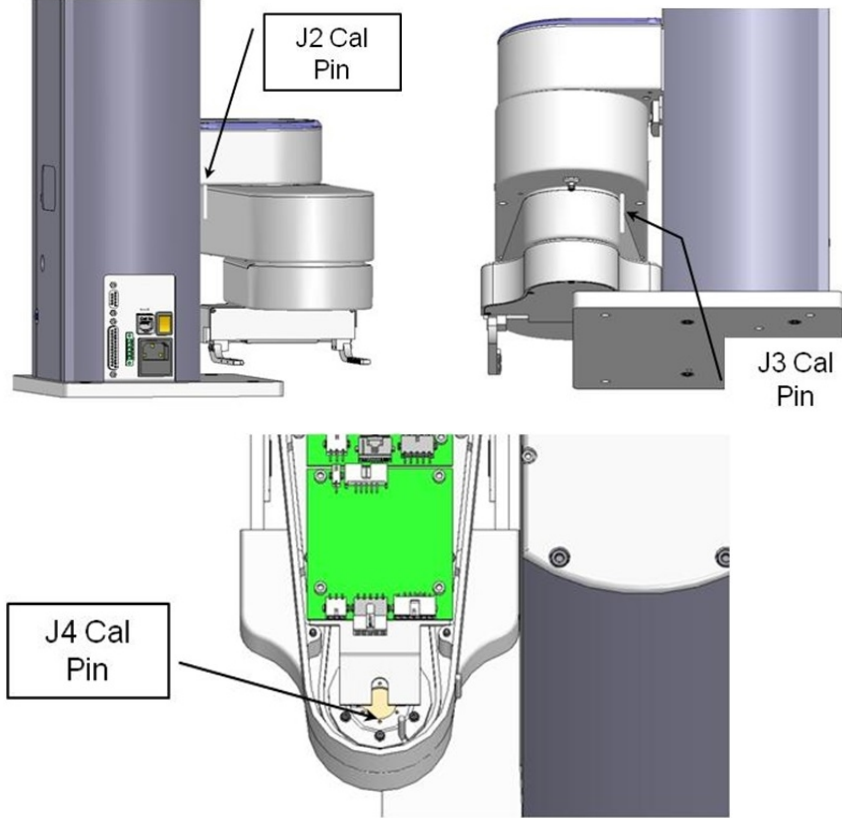
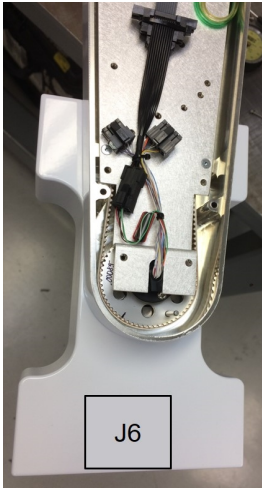
Step	Action
10.	<p data-bbox="342 275 1390 359">Insert an tapered 0.5 in Calibration Dowel Pin into the hole on inner link as shown below. Rotate outer link clockwise until it rests against the dowel pin. If the robot is installed on a linear rail, push the rail carriage all the way to the hard stop at the linear rail connector end cap.</p> 
11.	<p data-bbox="342 1310 1187 1341">For the Dual Gripper, J6 will be in the outwards orientation in the CALPP position.</p> 

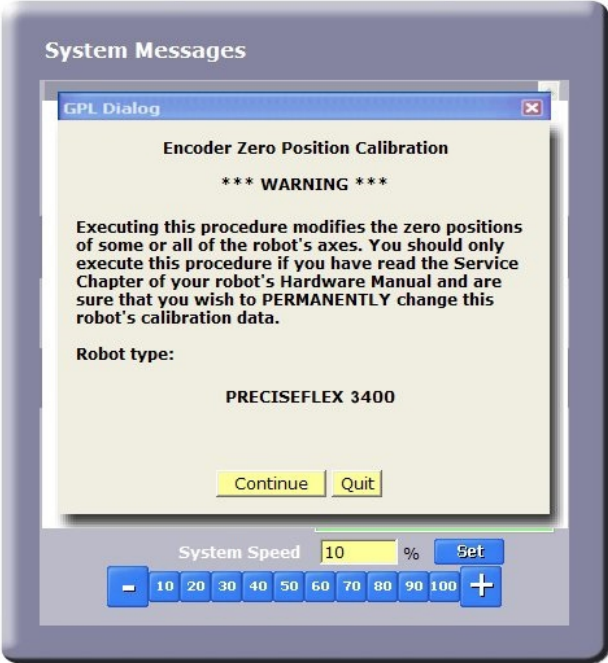
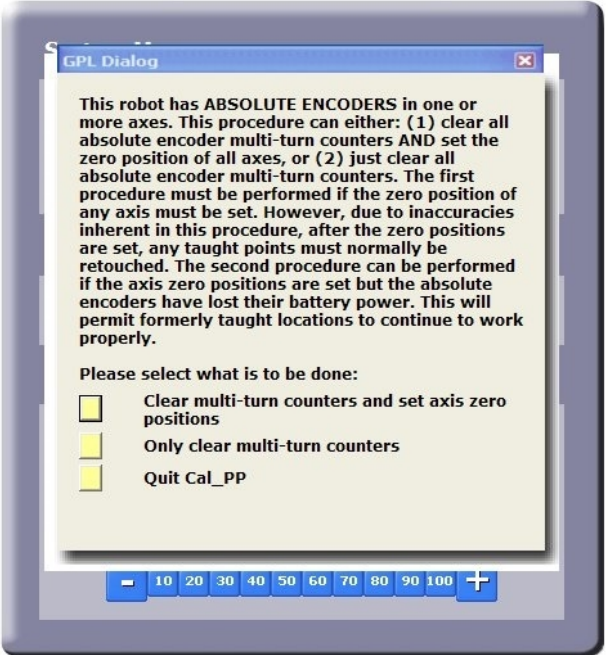
Step	Action
<p>12.</p>	<p>With the CALPP application loaded, select Start Application and then click Perform Operation. The application should start and prompt the user to confirm the correct robot position for calibration.</p> 
<p>13.</p>	<p>The CALPP application takes about 1 minute to run.</p> 

Step	Action
14.	After calibration is complete, use the brake release button and move the Z-axis up from the hard stop. Failing to do this will produce an error as the robot is outside of the soft stop limits.
15.	Ensure that the pins are removed.
16.	Enable power and home the robot. Calibration does not take effect until the robot is homed.

Replacing Belts and Motors



The timing belts and motors are designed to last the life of the robot. It is not expected that they will need to be replaced in the field. In most cases, if a belt or a motor needs to be replaced, the robot should be returned to the factory. While there are procedures at the end of this manual for replacing belts and motors, only experienced service technicians should attempt these procedures.

General Belt Tensioning

The PreciseFlex 400 has been designed to make belt tensioning very simple. Prior to 2014, each axis had a spring pre-load system that sets the correct belt tension when the axis motor mount plate screws are loosened. After 2014, the springs were removed from the inner and outer links and access hatches were added to make belt tensioning more accurate. See [Appendix E: Belt Tensions, Gates Tension Meter](#) for belt tension specifications.

Tensioning the J1 (Z Column) Belts

Tensioning the 1st Stage Belt

 DANGER Electrical Shock	
Before tensioning the timing belts or replacing any motors, the AC power should be disconnected. Removing the front cover allows access to the AC power terminals.	

Tools Required:

- 3.0 mm hex driver or hex L wrench

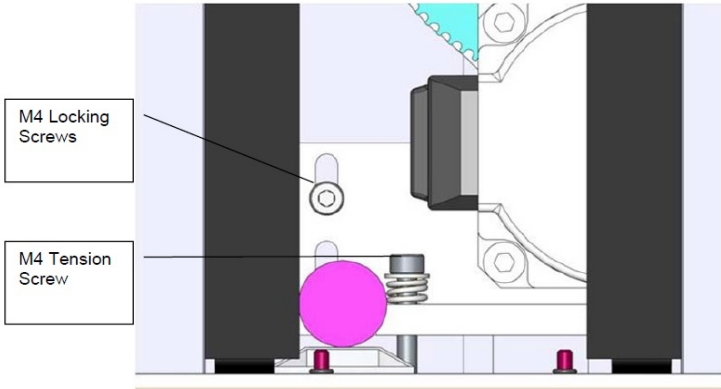
Step	Action
1.	Turn off robot power and remove the AC power cord.
2.	Remove the Top Plate of the robot by removing the (4) M5 socket head screws from the top plate of the robot that attach the top plate to the Z column. Lift up the Top Plate.
3.	Remove the Front Cover by lifting it out vertically.
4.	Loosen the (2) M4 locking screws on the J1 Motor Mount Bracket to allow the Mount Bracket to slide up and down.
5.	Adjust the M4 Tension Screw compressing the spring assembly. The tension spring should be compressed until the spring length is 5.5 mm under the washer.
6.	<p>After adjusting the Tension Screw, the M4 locking screws should be tightened to lock the assembly in place and the Front Cover and Top Plate should be replaced.</p>  <p>The diagram shows a cross-section of the motor mount assembly. Two vertical black bars represent the Z columns. A motor mount bracket is positioned between them. Two M4 locking screws are shown on the left side of the bracket, securing it to the Z column. An M4 tension screw is shown on the right side, passing through a spring assembly. Labels with leader lines point to the 'M4 Locking Screws' and the 'M4 Tension Screw'.</p>

Tensioning the 2nd Stage Belt



DANGER
Electrical Shock

Before tensioning the timing belts or replacing any motors, the AC power should be disconnected. Removing the front cover allows access to the AC power terminals.



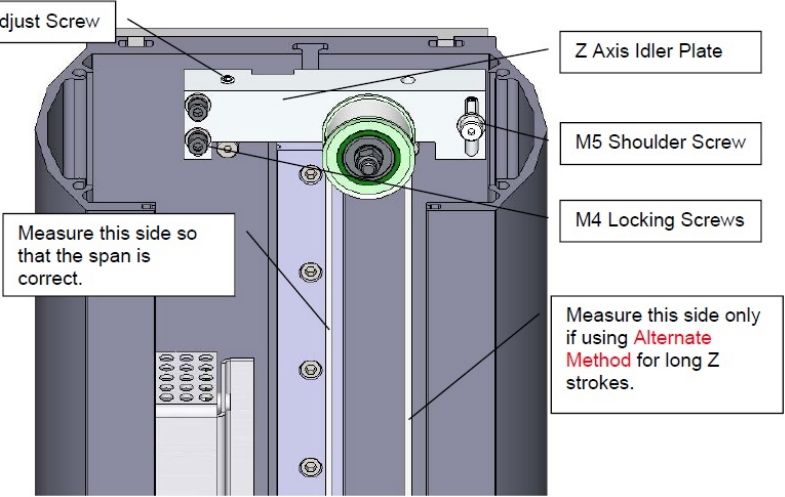

Tools Required:

- Gates Sonic Belt Tension Meter, Model 507C
- 3.0 mm hex driver or hex L wrench
- 2.5 mm hex driver or hex L wrench

Step	Action
1.	Turn off the robot power and remove the AC power cord.
2.	Remove the Top Plate of the robot by removing the (4) M5 socket head screws from the top plate of the robot that attach the top plate to the Z column. Lift up the Top Plate.
3.	Remove the Front Cover by lifting it out vertically.
4.	<p>Loosen the (2) M4 locking screws and the M5 shoulder screw on the Z idler plate.</p>  <p>The diagram shows a cross-section of the Z idler plate assembly. A central pulley is mounted on an M5 shoulder screw. Two M4 locking screws are positioned on either side of the pulley. A callout box on the left points to the pulley and says 'Measure this side so that the span is correct.' Another callout box on the right points to the pulley and says 'Measure this side only if using Alternate Method for long Z strokes.' Labels with leader lines identify the 'Tension Adjust Screw', 'Z Axis Idler Plate', 'M5 Shoulder Screw', and 'M4 Locking Screws'.</p>
5.	<p>The tension is set to the value in Appendix E: Belt Tensions, Gates Tension Meter by adjusting the M5 set screw which pushes on a spring in the Z Axis Idler Plate. Re-tighten the 3 screws and replace the Front Cover and Top Plate.</p> <p>Alternate Method: For the 750 mm and 1160 mm Z travel robots, it can sometimes be difficult to get a good tension reading for the spans for these long belts, which are 880 mm and 1290 mm respectively and as a result have low vibration frequencies. In this case it may be easier to position the Z carriage so that the span from the top idler pulley to the Z carriage is 530 mm, which is the span for the 400 mm Z stroke when measured on the left hand side of the belt as shown above. With the carriage at this location with a span of 530 mm, for these longer travel Z strokes, a user can then measure the tension on the right hand side of the belt, and use the values for tension and frequency for the 400 mm Z stroke.</p>

Tensioning the J2 Belt

 DANGER Electrical Shock	
Before tensioning the timing belts, the AC power should be disconnected. Removing the front cover allows access to the AC power terminals.	

Tools Required:

- Gates Sonic Belt Tension Meter, Model 507C
- 3.0 mm hex driver or hex L wrench
- 2.5 mm hex driver or hex L wrench
- 2.0 mm hex ball driver or hex L wrench

In order to re-tension the J2 (shoulder) Timing Belt, perform the following steps:

Step	Action
1.	Move the robot arm to the top of the Z Column travel.
2.	Turn off the robot power and remove the AC power cord.
3.	Remove the Top Plate of the robot by removing the (4) M5 socket head screws from the top plate of the robot that attach the top plate to the Z column. Lift up the Top Plate.

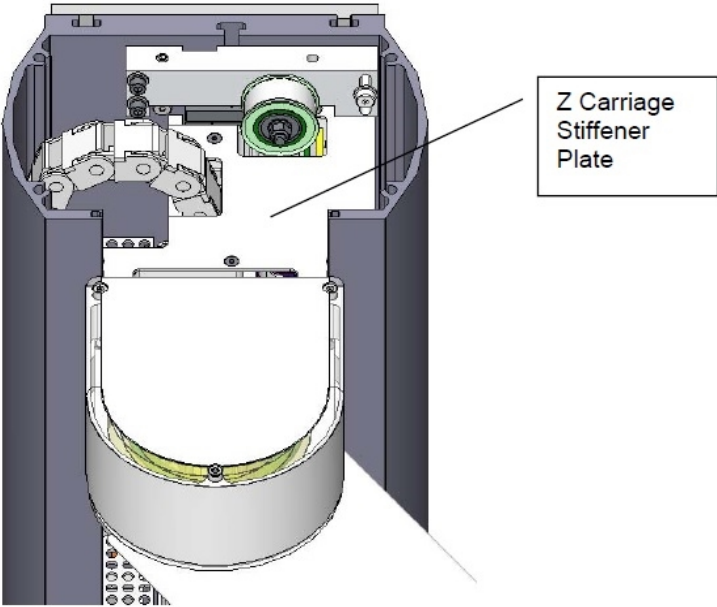
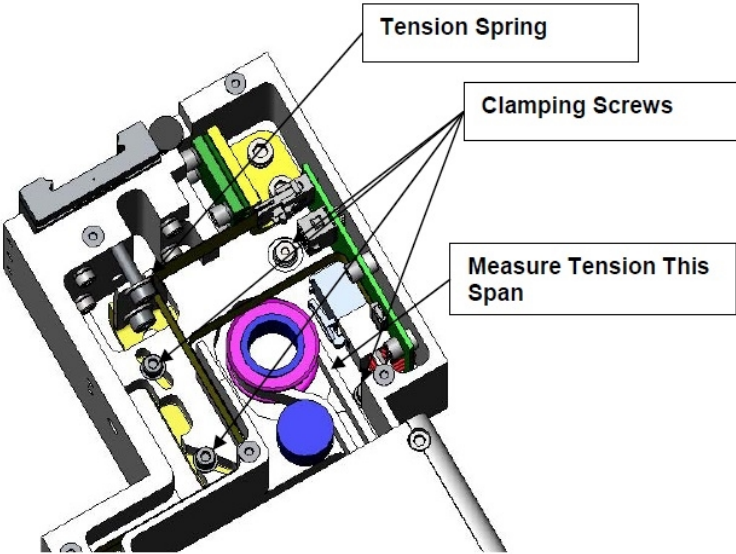
Step	Action
4.	<p>Remove the Front Cover by lifting it out vertically.</p>  <p>Z Carriage Stiffener Plate</p>
5.	<p>Remove the Z Carriage Stiffener Plate by removing the M3 X 6 FHCS attaching it to the Z Carriage (shoulder).</p>  <p>Tension Spring</p> <p>Clamping Screws</p> <p>Measure Tension This Span</p>

Step	Action
6.	Loosen the (3) M3 SHCS and (1) M4 Shoulder screw clamping the J2 Motor Mount Plate to the Z Carriage. It may be necessary to remove the tie wrap securing the J2 Motor cables to the Z carriage in order to access the clamping screw under these cables. It is best to measure the belt tension with a tension meter as described in Appendix E: Belt Tensions, Gates Tension Meter . If a belt tension meter is not available, the Tension Leaf Spring will automatically reset the belt tension. It is helpful to jiggle the motor a little bit to be sure any friction is overcome. The motor can be easily grasped by reaching under the Z carriage (shoulder). Then re-tighten the clamping screws. Replace the tie wrap if it was removed.
7.	Replace the Z Carriage Stiffener Plate.
8.	Replace the Front Cover.
9.	Replace the Top Plate.

Tensioning the J3 Belt (Before 2014)

Tools Required:

- Gates Sonic Belt Tension Meter, Model 507C
- 3.0 mm hex driver or hex L wrench
- 2.5 mm hex driver or hex L wrench

NOTE: Prior to 2014 the J3 belt had a simple tensioning procedure described below. If this did not work due to high friction in the motor mounting flange, then it became necessary to completely remove the robot controller to accurately tension the J3 belt. Starting with 2014 shipments, an access hatch was added to the bottom of both the inner link and outer link to make J3 and J4 belt access easy and belt tensioning more accurate.

Prior to 2014, to tension the J3 Belt, perform the following procedure:

Step	Action
1.	Loosen the (2) Motor Locking Screws on the bottom of the Inner Link. One screw requires a 2.5 mm driver and the second requires a 3.0 mm driver.
2.	Tighten the (2) screws again. The J3 belt is automatically re-tensioned.

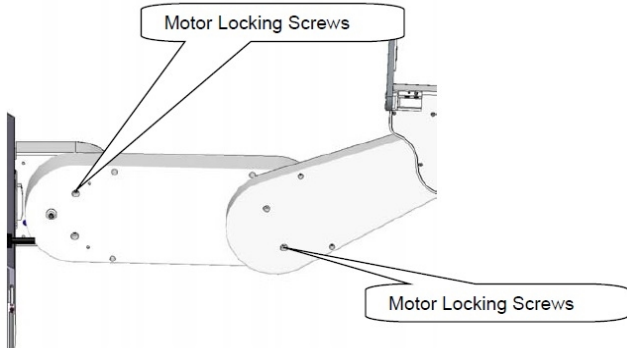
Step	Action
3.	<p>The above procedure is an approximate procedure. Its accuracy is limited by the fact that the J3 belt tension will vary according the orientation of the J3 output pulley. The timing belts are very stiff. A .002 in eccentricity (which is the specified tolerance) in the output pulley can cause a 50% variation in the belt tension, depending on the orientation of the output pulley.</p> <p>If performing the quick tensions adjustment outlined in Step 1 and Step 2 does not resolve a J3 instability (loud buzzing noise), it may be necessary to remove the controller and J3 belt cover to gain access to the J3 belt, and then set the belt tension by using a belt tension meter as described in Appendix E: Belt Tensions, Gates Tension Meter, while checking for the minimum belt tension every 10 degrees of rotation of the J3 output pulley. This more extensive procedure should be required only rarely.</p> 

Tensioning the J4 Belt (Before 2014)

Tools Required:

- Gates Sonic Belt Tension Meter, Model 507C
- 3.0 mm hex driver or hex L wrench
- 2.5 mm hex driver or hex L wrench

NOTE: Prior to 2014, the J4 belt had the tensioning procedure described below. Starting with 2014 shipments, an access hatch was added to the bottom of both the inner link and outer link to make J3 and J4 belt access easy and belt tensioning more accurate.

To tension the J4 Belt , performing the following procedure:

Step	Action
1.	Remove the outer link cover.

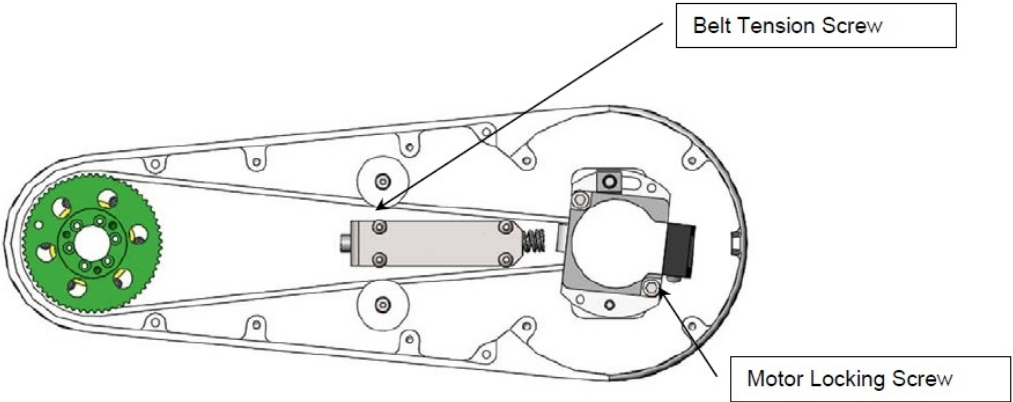

Step	Action
2.	Remove the gripper controller PCA.
3.	On robot sold before January 2012, remove the Slip Ring Clamp and remove the (4) M3 X 10 mm FHCS screws retaining the J4 belt cover. Tip the belt cover upwards to access the timing belt.
4.	Loosen the M4 SHCS and M4 Shoulder Motor Locking Screws on the bottom of the Outer Link.
5.	Measure the belt tension, every 10 degrees of rotation of the gripper to find the minimum tension.
6.	Adjust the minimum belt tension to the value in Appendix E: Belt Tensions, Gates Tension Meter . This may be possible by just releasing and re-tightening the Motor Locking Screws. It may require adjusting the Belt Tension Screw. For some earlier robots, the 18 mm M4 belt tension screw may need to be replaced with a longer 20, 22, or 24 mm M4 Socket Head Cap Screw in order to get enough tension.
7.	Tighten the (2) motor locking screws again.
8.	<p>For robots shipped after April 2012, an access hole has been cut in the J4 belt cover so that the tension meter head can reach the timing belt without tipping up the belt cover.</p>  <p>The diagram shows a top-down view of the J4 belt cover. A green gear is visible on the left side. A central motor assembly is shown with a horizontal shaft. Two screws are labeled: 'Belt Tension Screw' pointing to a screw on the motor assembly, and 'Motor Locking Screw' pointing to a screw on the motor housing. The access hole is located on the right side of the cover, allowing the tension meter head to reach the timing belt.</p>

Tensioning the J3 and J4 Belts (2014)

In 2014 the access hatches shown below were added to both the inner and outer links to facilitate belt tensioning. Once the hatch cover is removed, loosen the appropriate motor locking screws one turn to unclamp the motor.

NOTE: Do not loosen these screws more than one or two turns or the retaining nuts can fall off inside the link.

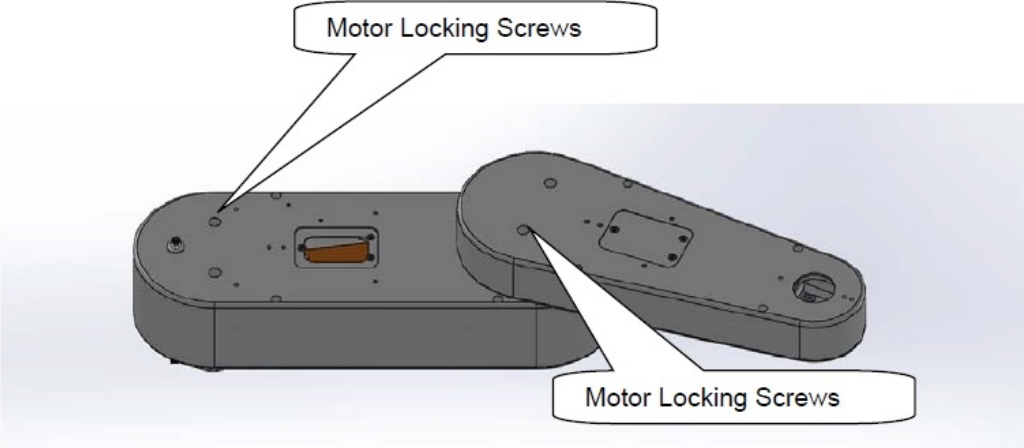
To tension the J3 and J4 belts (2014), perform the following procedure:

Step	Action
1.	<p data-bbox="321 268 1373 359">Insert the microphone from the belt tension meter near the belt to measure belt tension and adjust the M4 SHCS to adjust belt tension. Be sure to measure the belt tension eight times, at 45 increments of the pulley in the axis rotation and set the tension at the position that has the lowest tension.</p>  <p>The diagram shows two grey motor components. The left component is a rectangular motor housing with several screws. A callout box labeled 'Motor Locking Screws' points to one of these screws. The right component is a circular pulley with a central hole and a smaller hole on the side. A callout box labeled 'Motor Locking Screws' points to a screw on the pulley's surface.</p>
2.	 <p>The photograph shows a close-up of a yellow ribbed belt on a pulley. A black microphone is positioned near the belt. A callout box labeled 'Microphone on belt tension meter' points to the microphone. An L-shaped hex key is used to adjust a screw on the pulley. A callout box labeled 'Pluck belt gently with L key to measure tension.' points to the hex key.</p>

Tensioning the Belt on the Optional Linear Axis

Tools Required:

- Gates Sonic Belt Tension Meter, Model 507C
- 3.0 mm hex driver or hex L wrench

To tension the Linear Axis Belt:, perform the following procedure:

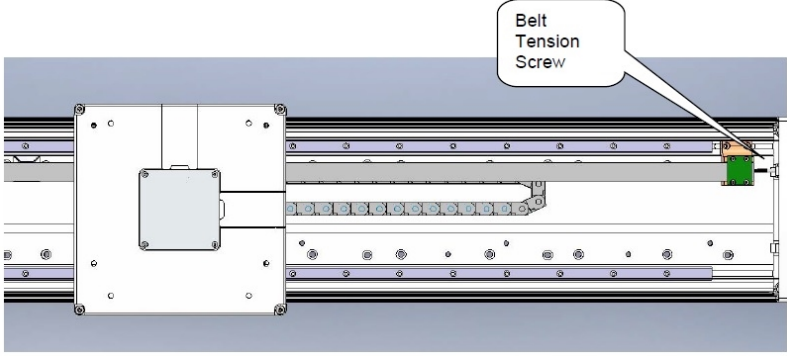
Step	Action
1.	Remove the linear axis cover by sliding the carriage to one end of travel, remove the (4) M4 X 30 mm SHCS from the end caps retaining the cover. It may also be necessary to loosen the connector end cap by loosening the screws attaching the connector end cap to the Linear Axis Extrusion, so that the cover can be lifted up and removed.
2.	Slide the carriage so that there is a 500 mm span of the belt between the belt tension clamp block and the idler roller on the carriage.
3.	Loosen the (2) clamping screws on the belt tension clamp block slightly. Adjust the belt tension screw to adjust the belt tension to the values in " Appendix E: Belt Tensions, Gates Tension Meter " on page 1. Tighten the clamping screws.
4.	Move the carriage back and forth the full length of travel and check the belt tension again.
5.	<p>Replace the cover.</p> 

Replacing the Power Supplies, Energy Dump PCA, or J1 Stage Two (Output) Timing Belt

DANGER
 Electrical Shock

Before replacing the power supplies, the AC power should be removed.



Tools Required:

- 3.0 mm hex driver or hex L wrench
- 2.5 mm hex driver or hex L wrench

Spare Parts Required:

- 24 VDC power supply, PS10-EP-24150 or
- 48 VDC power supply, PS10-EP-48400 or
- J1 Stage Two Belt, PN PF00-MC-X0022.

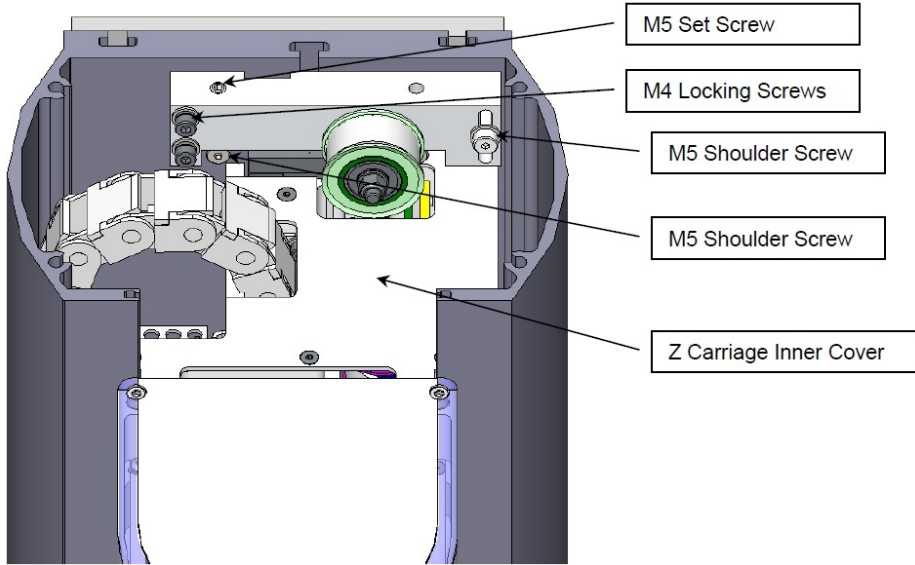

To replace the power supplies, Energy Dump PCA, or J1 Stage Two (Output) timing belt, perform the following procedure:

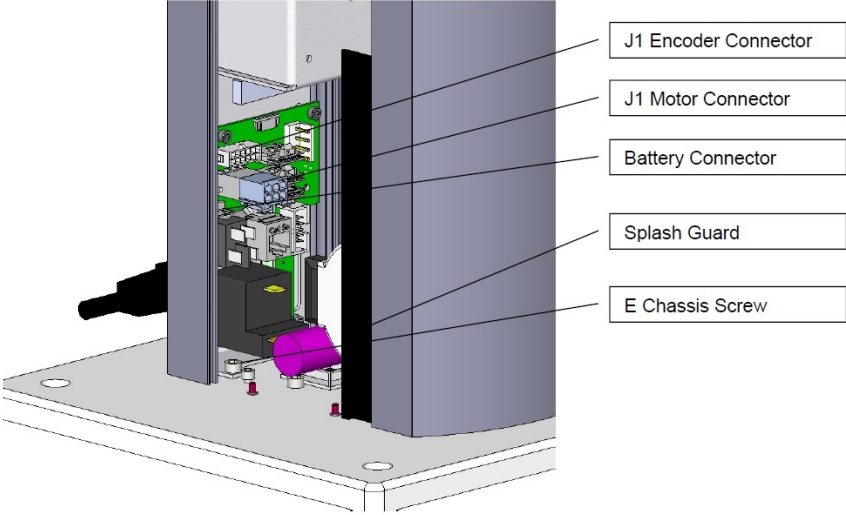
Step	Action
1.	Move the robot arm to the top of the Z Column travel.
2.	Turn off the robot power and remove the AC power cord.
3.	Remove the Top Plate of the robot by removing the (4) M5 socket head screws from the top plate of the robot that attach the top plate to the Z column. Lift up the Top Plate.
4.	<p>Remove the Front Cover by lifting it out vertically.</p> 
5.	Lay the robot down on its back side on a table where there is room to work.
6.	Remove the Idler Plate Assembly by removing the M5 set screw that compresses the Idler Plate Spring, the (2) M4 SHCS that clamp the Idler Plate, and the M5 Shoulder Screw that forms the Idler Plate pivot. Be careful not to drop the pressure washer and tension spring that are inside the Idler Plate assembly. The tension spring presses against an M5 shoulder screw to tension the Z-axis Stage 2 belt.
7.	Remove the remaining M5 shoulder screw.

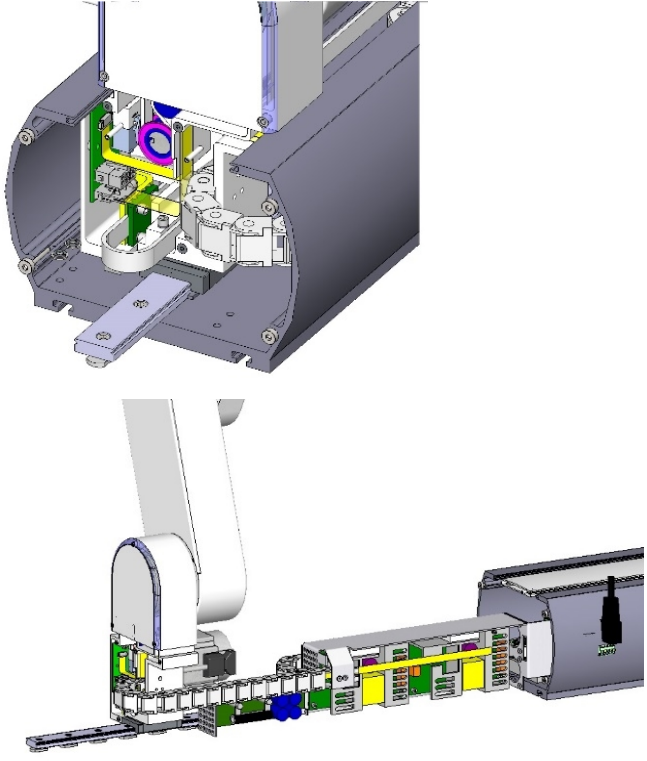
Step	Action
8.	Disengage the Z Carriage Timing Belt from the lower Drive Pulley. If it is necessary to replace the Z Carriage 2 nd Stage Timing Belt, remove the Z Carriage Inner Cover and then the Timing Belt Clamp from the Z carriage by removing the (2) M4 X 12 mm SHCS and lock washers and replace the belt.
9.	Remove the left splash guard by removing the M3 X 8 mm SHCS on the retaining bracket.
10.	<p>Remove the (4) screws that hold the Electronic Chassis to the Z Extrusion and the (2) screws that attach the Electronic Chassis and ground wire to the Base Plate.</p> 
11.	Remove the J1 motor and encoder connectors that plug into the J1 Motor Interface Board.
12.	Remove the Battery connector that plugs into the J1 Motor Interface Board.
13.	Loosen the M4 SHCS screws attaching the Z bearing rail to the Z Extrusion.
14.	Slide the Z Rail and Z Carriage with the robot arm still attached partially out the top of the robot, far enough to expose the power supplies. It may be more convenient to slide the carriage and Z rail all the way out of the Z extrusion. Take care the bearing block does not slide off the Z rail. It may be helpful to wrap some tape around the rail to prevent this. If the bearing block slides off the rail, the bearing balls may be lost, damaging the bearing. Simultaneously slide the Electronic Chassis out of the Z Extrusion and lay both assemblies on the table.
15.	Unplug the cables from the failed power supply.

Step	Action
16.	<p>Remove the (4) M3 X 8 mm SHCS and lock washers to replace the power supply or energy dump PCA. Be careful not to pull the J1 FFC encoder cable (white 14 mm wide flat cable) out of the FFC connector on the J1 Motor Interface PCA. If this cable is pulled out, carefully release the clamping lid on the FFC cable connector on the J1 Motor Interface PCA by inserting a small flat bladed screwdriver in the notch in the clamping lid and very gently prying the lid out of the connector. This lid is a cam-lock type of lid, which when inserted, clamps the flat white J1 encoder ribbon cable. Re-insert the J1 flat white encoder ribbon cable into this connector and carefully press the clamping lid back into the connector.</p> <p>If the J1 encoder cable is disconnected during this procedure, it will be necessary to re-calibrate the robot as the absolute encoder backup power will be interrupted to the J1 absolute encoder.</p>
17.	<p>Re-attach the power supply cables and re-assemble the robot. Ensure that the bearing rail reference edge is tightly pressed against the reference boss in the Z extrusion. The top of the bearing rail should be about 35 mm below the top of the extrusion and the bottom of the rail should clear the stage one Z timing belt on the large diameter pulley.</p>
18.	<p>Recalibrate the robot.</p> 

Replacing the Robot Controller

 DANGER Electrical Shock	
<p>Before replacing the Robot Controller, the AC power should be removed.</p>	

Tools Required:

- 2.5 mm hex driver or hex L wrench
- 2.0 mm hex driver or hex L wrench
- Small flat bladed screw driver, with 1.5 mm wide blade type
- M5 socket driver or M5 open end wrench or pliers

Spare Parts Required:

- Guidance G1400B Controller PN G1X0-EA-B1400-12A

Prior to replacing the controller, the user may want to make copies of both the robot PAC files, and any project files to a PC, using a procedure similar to that described in [Loading a Project \(Program\) or Updating PAC Files](#).

To replace the Robot Controller, perform the following procedure:

Step	Action
1.	Turn off the robot power and remove the AC power cord.
2.	Remove the Inner Link Cover by removing the (4) M3 X 20 mm SHCS that attach the cover.
3.	Remove the upper circuit board by removing the (4) M2.5 X 6 mm screws.
4.	Unplug the cables from upper circuit board.
5.	Remove the lower circuit board by removing the (4) M2.5 X 16 mm standoffs with an M5 socket driver.
6.	Unplug the cables from the lower circuit board. Use a small flat bladed screwdriver to gently release the 3 zero-insertion-force (ZIF) flat flexible cable (FFC) connector compression lids.
7.	Check the jumpers on the replacement CPU board (top board) per the photo in Step 12.

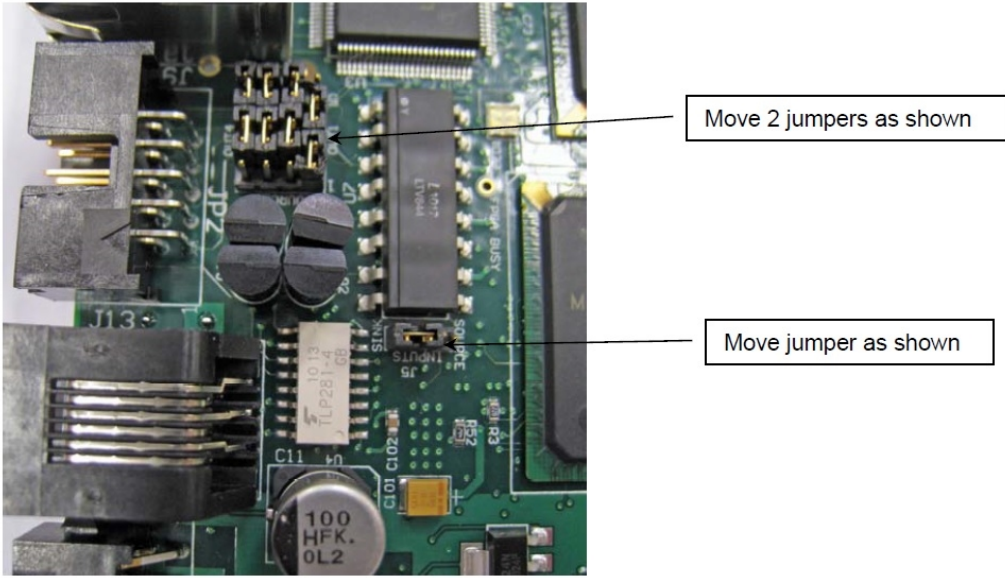
Step	Action
8.	Re-attach the harness and replace the circuit boards. Refer to the schematics section above for connector labeling on the circuit boards. Be careful that the 2-pin plug from the brake release switch plugs into the lower board and the 2-pin plug on the pigtail from the lower board plugs into the upper board. Be careful to gently press in the compression latch on the FFC encoder connectors with your finger, not a sharp object.
9.	Make sure the Ethernet cable folds back along the under the upper circuit board but does not obstruct the board to board connector.
10.	Make sure no cables will be pinched by the Inner Link Cover and replace the Cover.
11.	After replacing the Robot Controller the robot must be re-calibrated. See Calibrating the Robot: Setting the Encoder Zero Positions .
12.	After replacing the Robot Controller, the BenchBot PAC files and BenchBot application program must be installed. (These may be pre-installed by Agilent Field Service). <div style="text-align: center;">  </div>

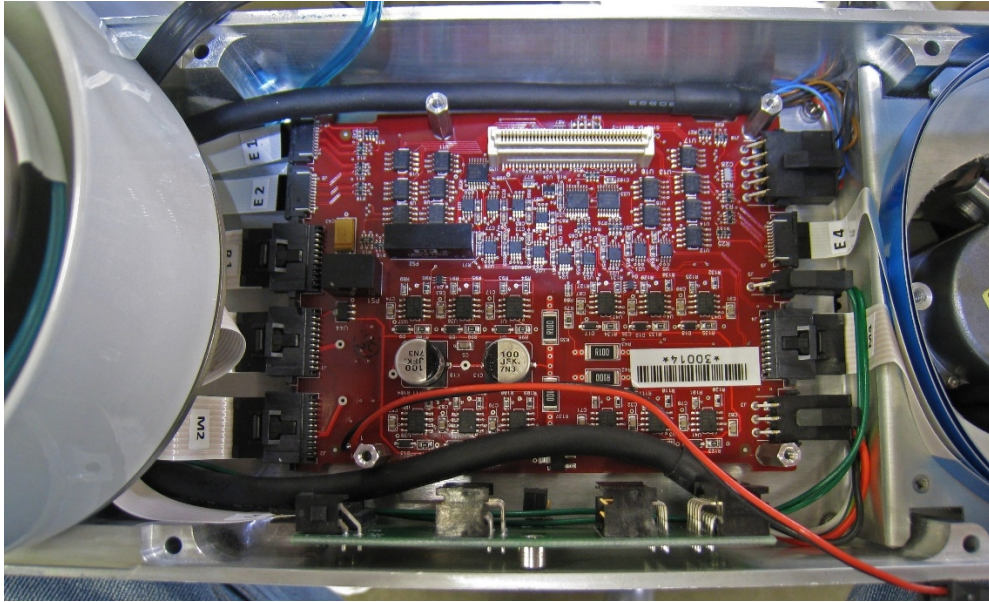



Figure 2-1: Power Amplifier Installed in Inner Link



Figure 2-2: Controller Installed in Inner Link

Replacing the Servo Gripper Controller

 DANGER Electrical Shock	
Before replacing the Gripper Controller, the AC power should be removed.	

Tools Required:

- 2.5 mm hex driver or hex L wrench

Spare Parts Required:

- For the 23N PF400 Servo Gripper: Guidance Gripper Controller P/N G1X0-EA-T1100 or G1X0-EA-T1101

To replace the Gripper Controller, perform the following procedure:

Step	Action
1.	Turn off the robot power and remove the AC power cord.
2.	Remove the Outer Link Cover.
3.	Remove the Gripper Controller by removing the (4) M3 X 10 mm SHCS and unplugging the cables.
4.	Replace the Gripper Controller and re-attach the harness.
5.	Replace the Outer Link Cover.
6.	It is not necessary to recalibrate the robot after replacing the Gripper Controller. Starting January of 2013 gripper controllers are a new revision (GSB3), which replaces the address DIP switch with jumpers. To make the software in the GSB3 work in a compatible mode with the standard PAC files, Jumper J11 must be removed.

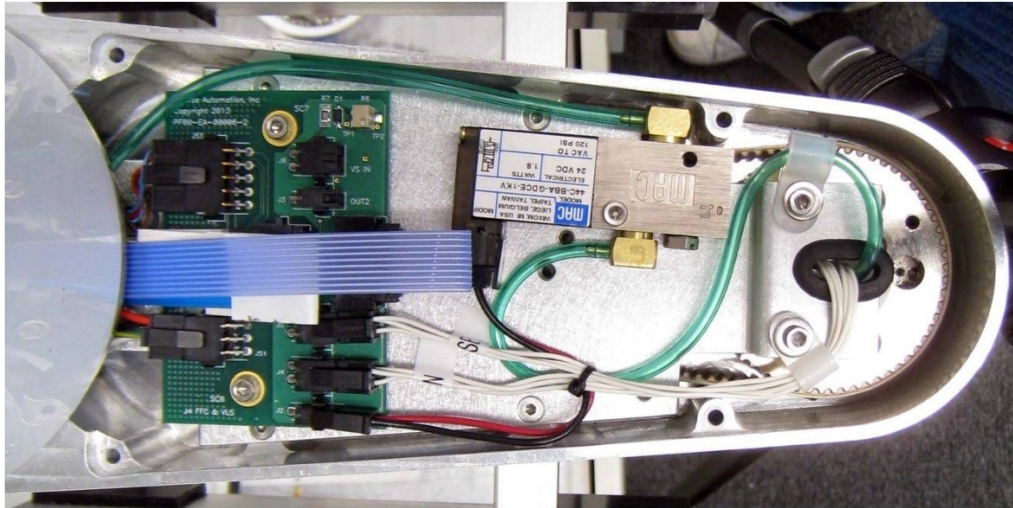

Figure 2-3: Wiring for Pneumatic Gripper

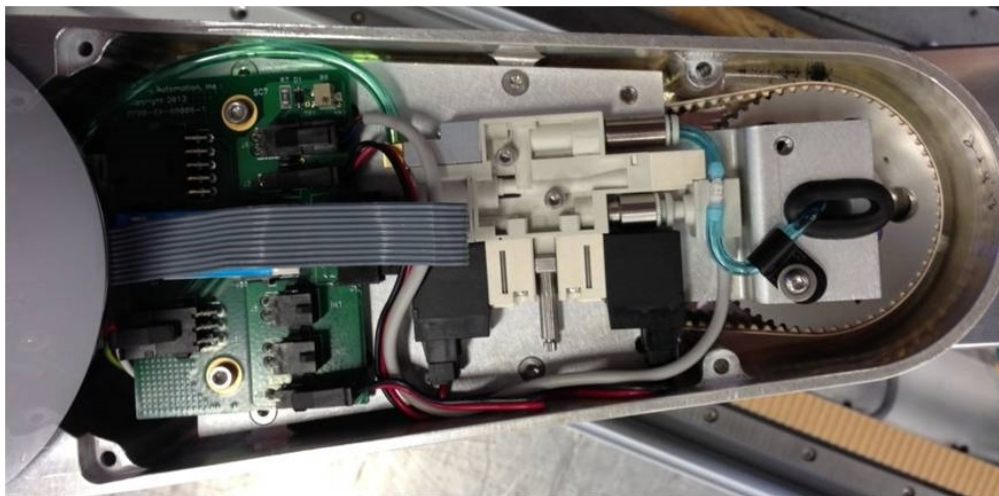

Figure 2-4: Wiring for Vacuum Gripper

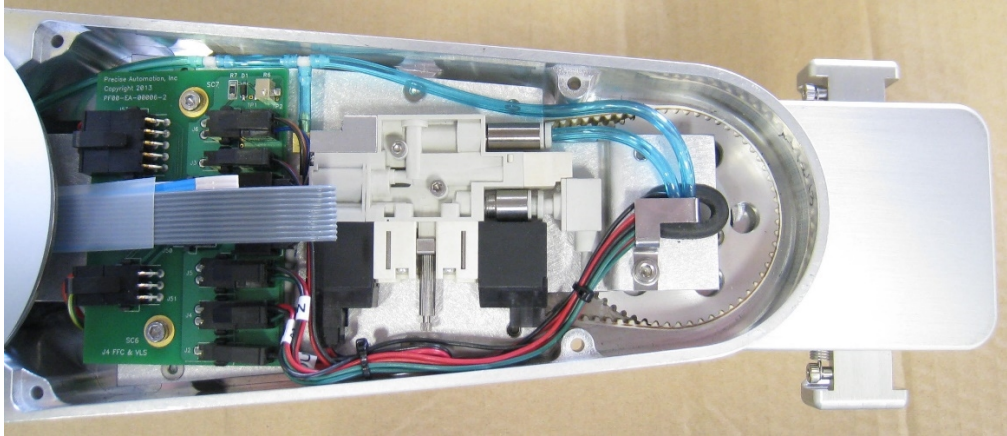

Figure 2-5: Wiring for Vacuum-Pallet Gripper

Replacing the Agilent Servo Gripper Finger Pads

Tools Required:

- 1.3 mm hex driver or hex L wrench

Spare Parts Required:

- Guidance G1400B Controller PN G1X0-EA-B1400-12A, set of (4) pads.

To replace the Gripper Finger Pads, perform the following procedure:

Step	Action
1.	Remove the (3) M2 X 6 mm FHS to remove the Spline Bumper Plates.
2.	Replace the Finger Pads by pressing new pads into the Spline Bumper Plates.

Step	Action
3.	<p>Re-attach the Spline Bumper Plates. Do not use Loctite.</p> 

Replacing the Gripper Spring or Cable

Tools Required:

- 1.3 mm hex driver
- 2.5 mm hex driver
- 7 mm open end wrench
- Loctite 222

Spare Parts Required:

- Spring or Cable Assembly

To replace the spring or cable, perform the following procedure:

Step	Action
1.	Remove the Gripper Cover by removing the (4) or (6) M2 X 6 mm FHCS (depends on model).
2.	Remove the spring cable assembly by removing the M3 screws shown in Step 3.

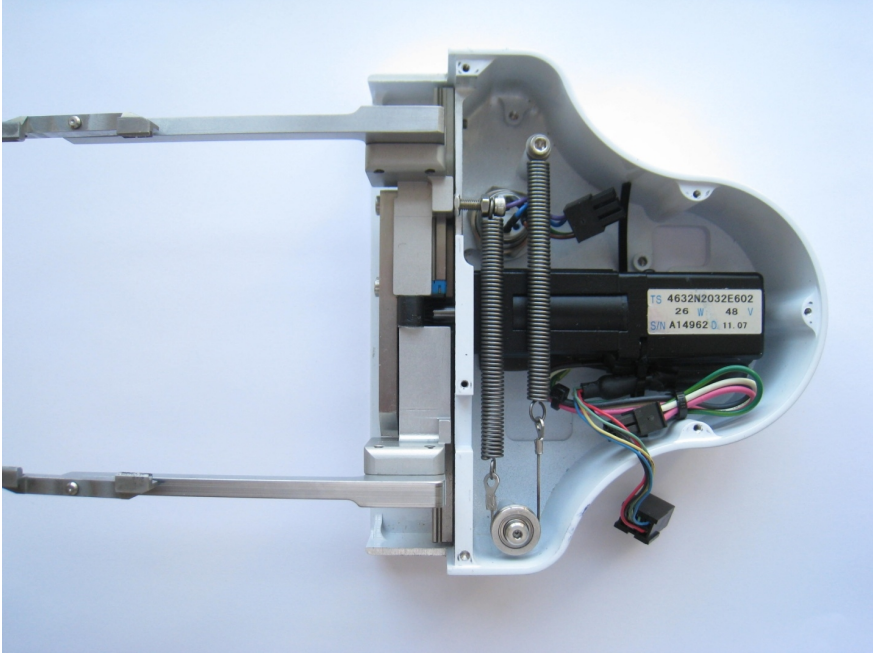
Step	Action
3.	<p>Replace the spring cable assembly and replace the cover.</p> 

Adjusting the Gripper Backlash or Centering Fingers

Tools Required:

- 1.3 mm “stubby” hex L wrench
- 1.5 mm “stubby” hex L wrench

Spare Parts Required: none

To adjust the gripper backlash, perform the following procedure:

Step	Action
1.	Remove the Gripper Cover by removing the (6) M2 X 6 mm FHCS.
2.	For grippers with spring return, disconnect one end of the spring to remove spring tension.
3.	Move the racks back and forth to determine which rack has backlash and where it is located on the rack.
4.	Loosen the (2) M3 X 8 mm SHCS that clamp the rack to the finger mount.

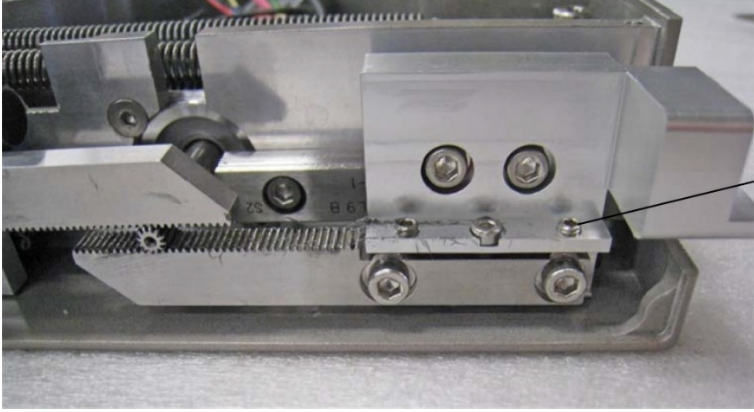
Step	Action
5.	Adjust the M2 SHCS and M3 set screws to adjust the rack backlash or center the racks as needed if a crash has caused the racks to skip teeth or come loose.
6.	<p>Remove the (2) M3 X 8 mm SHCS one at a time, apply Loctite 243 screwlock, and reinstall and tighten.</p> 

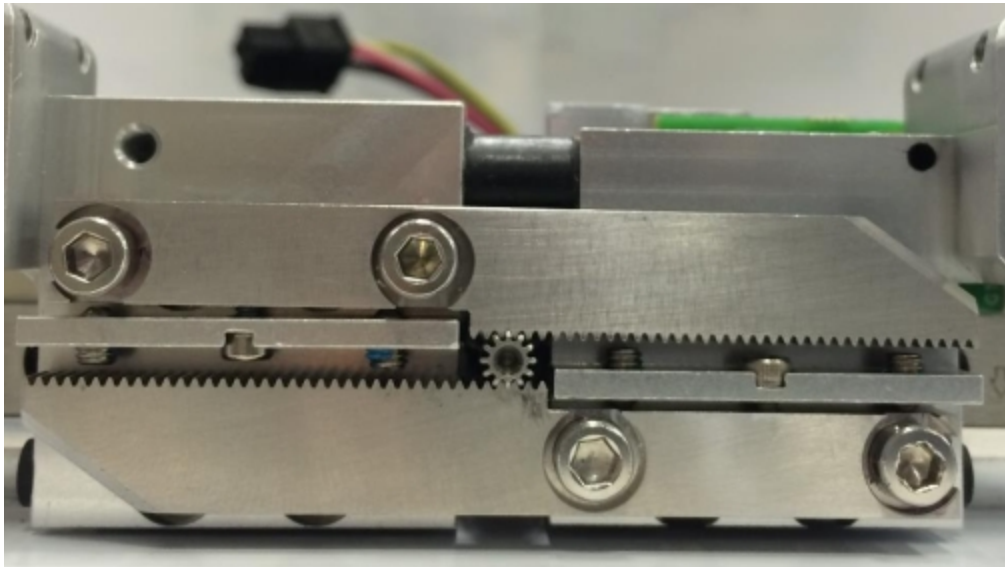

Figure 2-6: Gripper Racks Centered in Fully Closed Position

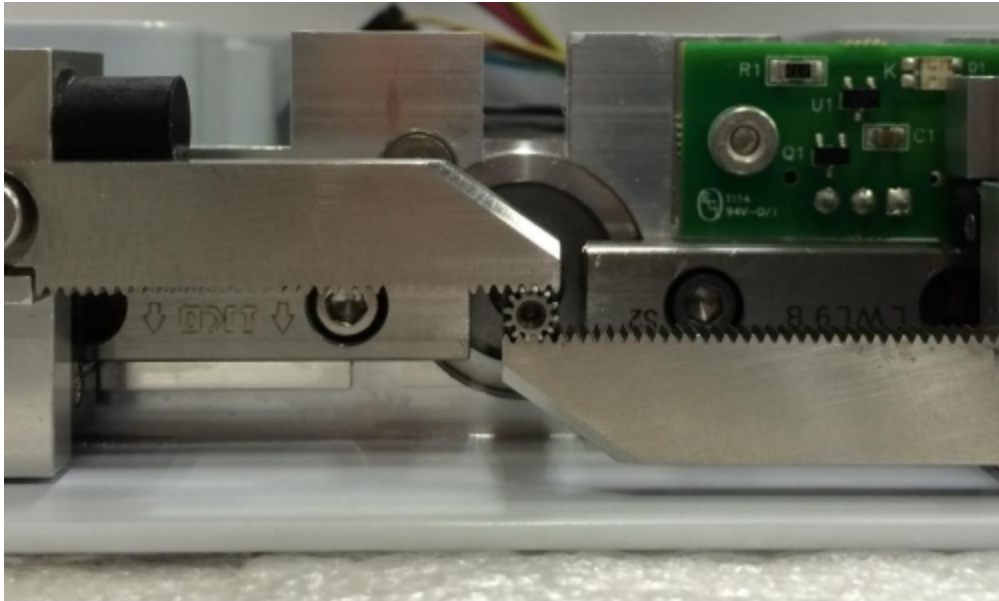

Figure 2-7: Gripper Racks Centered in Fully Open Position

Adjusting the Gripper Brake (for Grippers with Brake)

Tools Required:

- 1.3 mm hex driver
- 5.5 mm open end wrench
- Loctite 222



Spare Parts Required: none

To adjust the gripper brake, perform the following procedure:

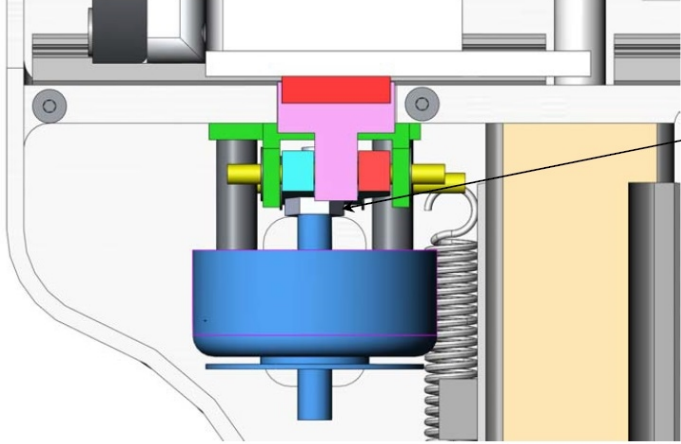
Step	Action
1.	Remove the Gripper Cover by removing the (6) M2 X 6 mm FHCS.
2.	Energize the brake to activate the solenoid to release the brake.
3.	Check the clearance between the brake shoe and the finger mount brake surface. This clearance should be between .1 mm (.004 in) and .25 mm (.010 in), and the gripper fingers should slide freely.
4.	If necessary, use a 5.5 mm open end wrench to adjust the M3 X 6 mm hex head screw that adjusts the brake backlash. This screw should be backed out 2 mm, Loctite 222 applied to the screw threads, and then screwed back in to the brake lever to set the brake clearance.
5.	Make sure the brake pad is held up in the brake notch in the gripper wall and engage the brake.

Step	Action
6.	<p>Replace the cover.</p> 

Replacing the Electric Grippers or Slip Ring Harness

 DANGER Electrical Shock	
<p>Before replacing the Gripper Harness, the AC power should be removed.</p>	

Tools Required:

- 2.5 mm hex driver or hex L wrench
- 2.0 mm hex driver
- 1.5 mm hex driver
- 1.3 mm hex driver

Spare Parts Required for Gripper, one of the following:

- Low Profile 23 N Electric Gripper™ PreciseFlex P/N PF0A-MA-00001 (Agilent)
- PF400 23 N Servo Gripper without fingers PreciseFlex P/N PF04-MA-00010-E13 (Standard)

Spare Parts Required for Slip Ring, one of the following:

- PF400 Slip Ring Harness Assembly, 23 N Brake Gripper (Agilent) PF04-MA-00002
- PF400 Slip Ring Harness Assembly, 23 N Spring Gripper (Standard) PF04-MA-00010

To replace the Gripper, perform the following procedure:

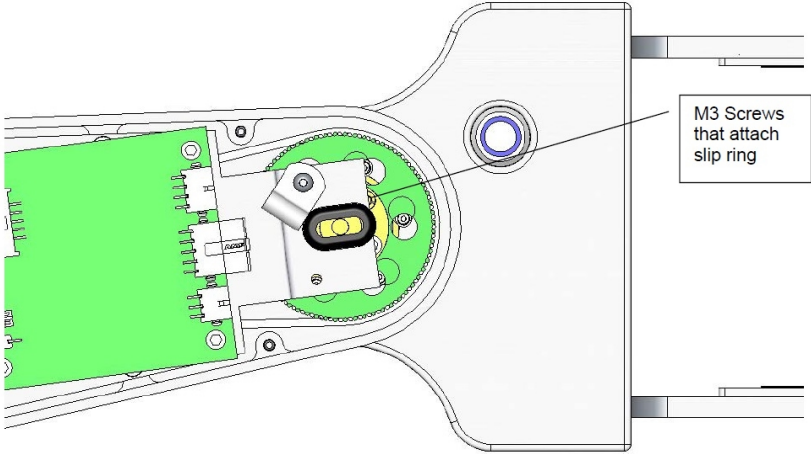
Step	Action
1.	Turn off the robot power and remove the AC power cord.
2.	Remove the Outer Link Cover.
3.	Remove the Gripper Controller and P Clamp holding the slip ring cable. Slide the grommet out of the notch in the belt cover.
4.	<p>Remove the (4) M3 FHCS that attach the belt cover. Tip up the belt cover and slide a pencil under it to hold it up to provide access to the slip ring flange.</p> 
5.	Rotate the Gripper so that the (3) M3 X 6 mm BHCS which attach the Slip Ring to the J4 Output. The pulley can be removed one by one through the notch in the Outer Link Belt Cover.
6.	Remove the bottom cover from the Gripper by removing the (6) M2 X 6 mm FHCS.
7.	Disconnect the Slip Ring harness (4 plugs) from the Gripper harness.
8.	Rotate the Slip Ring housing 30 degrees to allow access to (3) of (6) M2 X 16 mm SHCS. Loosen these screws. Rotate the Slip Ring housing 30 degrees in the opposite direction to access and loosen the remaining (3) screws.
9.	Gently pull the Gripper down a few centimeters and slide the Slip Ring harness and connectors through the access hole in the Gripper housing.

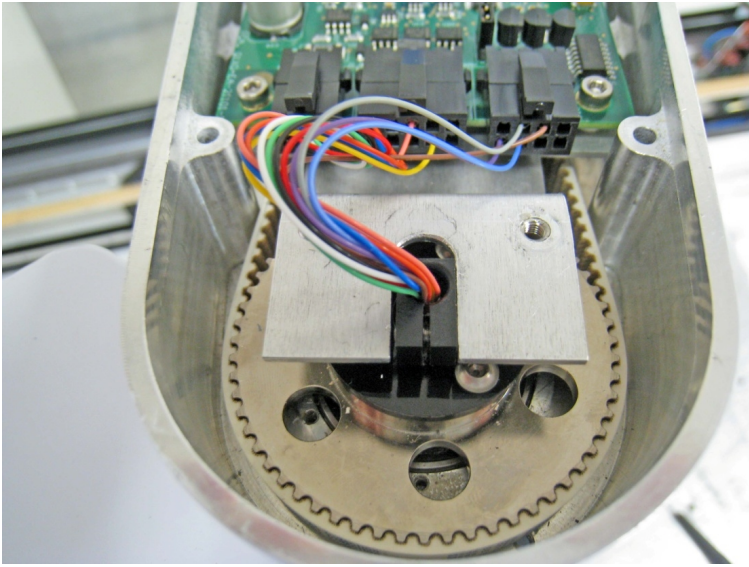
Step	Action
10.	<p>At this point the slip ring harness can be replaced if necessary.</p> 
11.	<p>After the slip ring is installed, rotation of the wire bundle must be prevented by attaching a black Delrin clamp around the slip ring hub. This clamp is slotted so that it can be slipped over the wires and attached to the hub with a M2.5 X 6 mm SHCS. Some older slip rings had heat shrink tube over the hub. This should be removed when attaching the Delrin Clamp.</p>
12.	<p>Replace the Gripper and re-attach the new Gripper. Ensure that the dowel pin in the wrist pulley flange is located in the notch in the top of the gripper housing. Ensure that the slip ring wires do not get pinched during re-assembly.</p>
13.	<p>It is not necessary to re-calibrate the robot after replacing the 23N Gripper.</p>

Replacing the Linear Axis Controller

Tools Required:

- 2.5 mm hex driver or hex L wrench
- 2.0 mm hex driver

Spare Parts Required:

- G1100T Slave Controller (“GSB3-DIFF”) see “Spare Parts List.” Note this part has differential encoder inputs and is not the same part as the GSB3-SE for the gripper, which has single ended encoder inputs.

To replace the Linear Axis Controller, perform the following procedure:

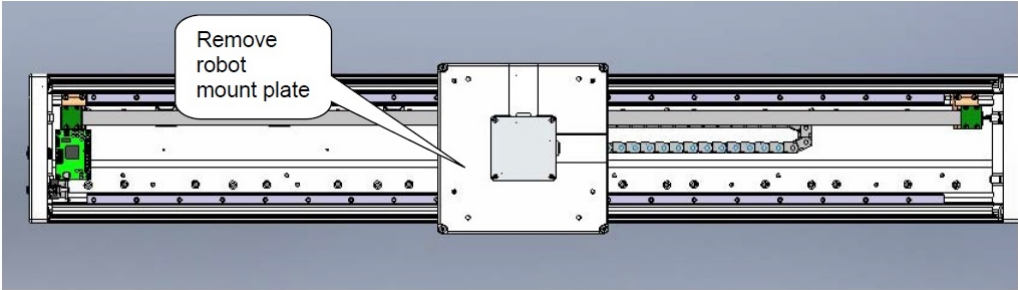
Step	Action
1.	Remove the linear axis cover by sliding the carriage to one end of travel, remove the (4) M4 X 30 mm SHCS from the end caps retaining the cover. It may also be necessary to loosen the connector end cap by loosening the bottom (2) screws that attach the connector end cap to the Linear Axis Extrusion, so that the cover can be lifted up and removed.
2.	Remove the cable covers on the robot mount plate. Remove the robot mount plate.
3.	<p>Replace the Linear Axis Controller Board. Ensure that all jumpers are set as shown below and that the battery wires are re-connected as shown. It will be necessary to recalibrate the robot if this board is replaced and the absolute encoder battery wires are disconnected.</p> 

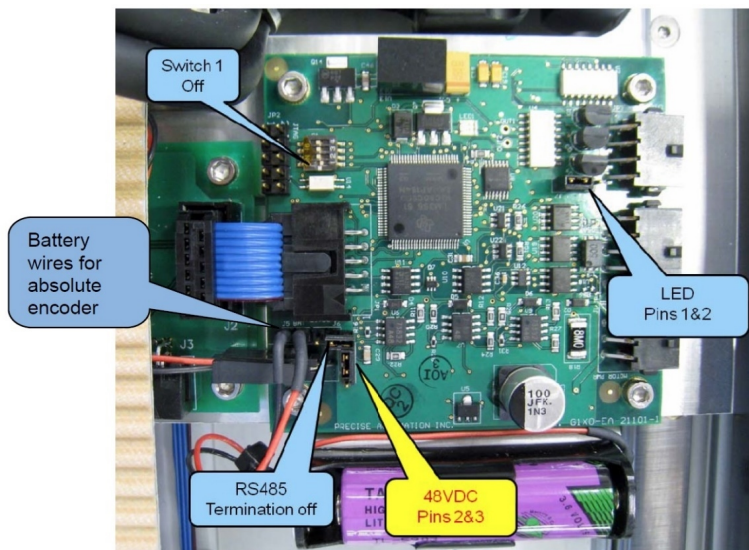

Figure 2-8: Linear Axis Controller (GSB Revision 2)

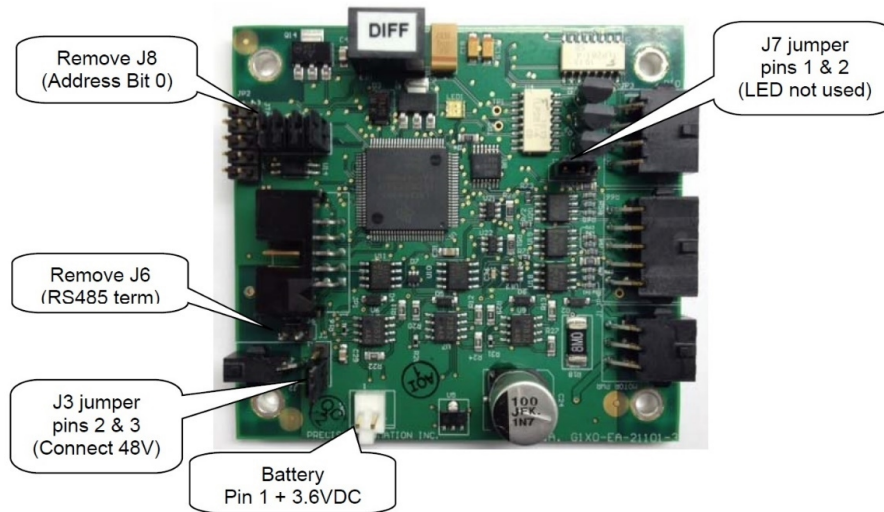

Figure 2-9: Linear Axis Controller Rev2 (GSB Revision 3)

Installing the Optional GIO Board

Brooks sells a digital IO board that provides 12 inputs and 8 outputs as an option. This board may be installed either in the Z column of the robot for standalone PF400 robots, or in the Linear Axis extrusion for robots with the Linear Axis option.

This board is provided with a 150 mm pigtail harness to a 25-pin Dsub connector. The board is attached with (4) M3 X 10 mm SHCS and the 25-pin Dsub is attached with standard D-sub 4-40 mounting standoffs.

This board is typically installed at the factory, but can be installed in the field for robots shipped after July 2012 which have the appropriate mounting holes.

Tools Required:

- 3 mm hex driver or hex L wrench
- 2.5 mm hex driver
- M5 socket driver
- M5 open end wrench

Spare Parts Required:

- GIO Digital IO Board see "Spare Parts List"

To install the GIO Board in a robot without a linear axis, perform the following procedure:

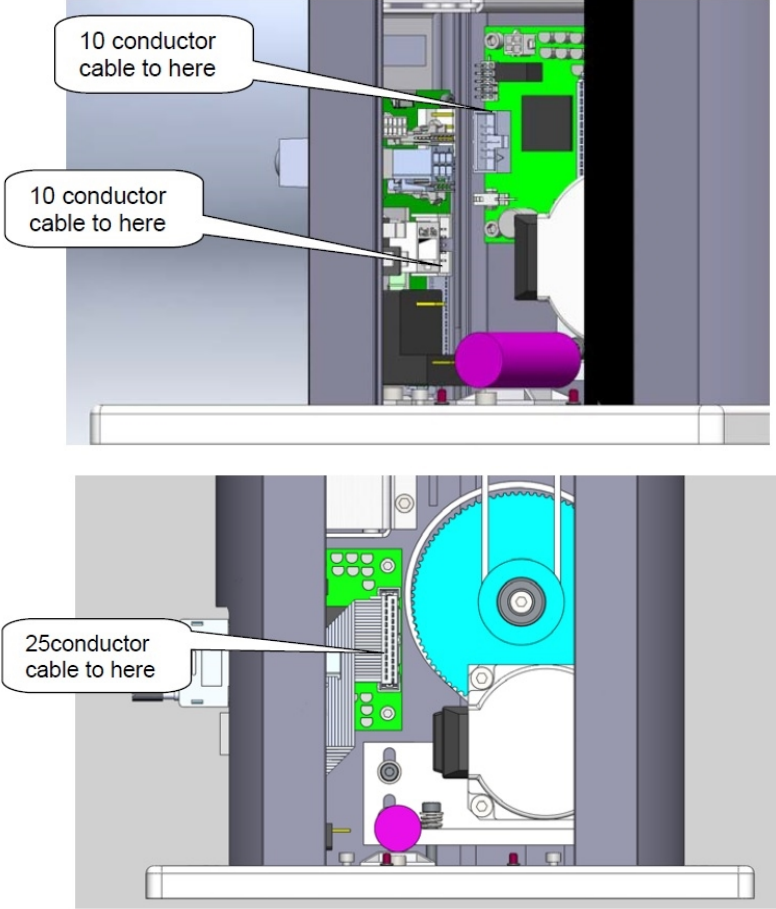
Step	Action
1.	Remove the top cover plate from the top of the robot Z column by removing the (4) M5 X 10 mm LHCS.
2.	Remove the front Z column cover by sliding it upwards through the Z carriage.
3.	<p>Remove the left splash guard by removing the M3 X 8 mm SHCS and star washer holding the splash guard to the robot base plate.</p> 
4.	Disconnect the Ethernet cable and move it out of the way if necessary.
5.	Remove the 25-pin Dsub blank cover plate from the connector panel by removing the M3 BHCS. These screws are retained by M3 nylon insert hex nuts on the back of the front connector panel.
6.	Remove all (4) address jumpers on the GIO board J8-J11. See Step 3.
7.	Install the GIO board with the (4) M3 X 10 mm SHCS on the rear surface of the Z column as shown in Step 3.
8.	Install the 10 conductor RS-485 jumper cable from the GIO board to the connector panel board.

Step	Action
9.	Attach the 25-pin Dsub connector pigtail to the connector panel with the 4-40 standoff kit and plug the 26-pin connector into the GIO board. Be careful to fold the harness to the D sub as shown in Step 3.
10.	Reconnect the Ethernet cable.
11.	Replace the covers.
12.	Set value 8 in Data ID 151 to "GIO_8", so that this ID reads "<Controller Serial No>", "GSB_1", "GIO_8" This parameter may be found in Setup/Parameter Database/Controller/System ID.
13.	GIO signals may then be checked under Control Panels/Remote IO/Network Node 8.
14.	Remove the RS-485 J6 termination jumper on the controller board in the inner link.

To install the GIO Board in a robot with a Linear Axis, perform the following procedure:

Step	Action
1.	Slide the carriage of the Linear Axis to one end of travel.
2.	Remove the top cover from the Linear Axis by removing the (4) M4 X 30 mm SHCS from the end caps. It may be necessary to loosen the (2) bottom screws on the connector end cap to provide clearance to remove the cover.
3.	<p>Remove all (4) address jumpers on the GIO board J7-J10, as shown.</p> <p>Digital Outputs 1-8 Default Position is sinking. Moving both jumpers up 1 pin for sourcing</p> <p>Install J6 (RS485 Term)</p> <p>Remove J7, J8, J9, J10</p> <p>J2: Digital/Analog Input 12 Connect Pins 1&2 for digital input</p> <p>J5: Digital Inputs 19-12 sourcing position</p> <p>J1: Digital/Analog Input 11 Connect Pins 1&2 for digital input</p> <p>J4: Digital Inputs 5-8 sourcing position</p> <p>J3: Digital Inputs 1-4 sourcing position</p>

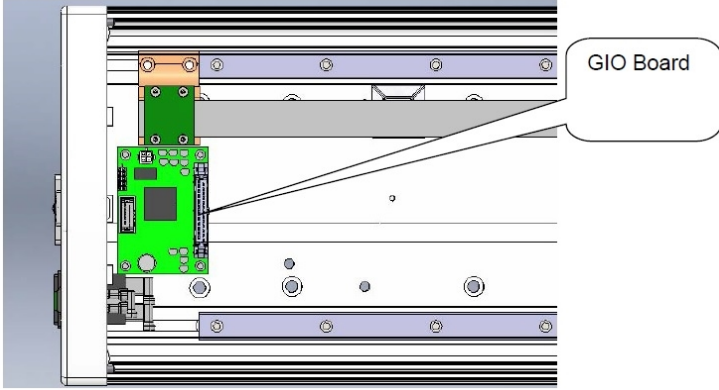
Step	Action
4.	<p>Install the GIO Board in the linear axis using the (4) M3 X 10 mm SHCS and lockwashers.</p> 
5.	<p>Remove the termination resistor from the 10-pin connector plug attached by (4) wires to the 9-pin Dsub Pendant connector and plug the 10-pin connector into the GIO board.</p>
6.	<p>Install the GIO output pigtail by plugging the 26-pin connector into to the GIO board and attaching the 25-pin Dsub connector to the end cap with the 4-40 standoffs provided. Make an accordion fold with the extra ribbon cable and tie wrap to hold the fold down over the GIO board.</p>
7.	<p>Replace the covers.</p>
8.	<p>Set value 8 in Data ID 151 to "GIO_8", so that this ID reads "<Controller Serial No>", "GSB_1", "GIO_8" <small>633 633 633 633 633</small> <small>3 3 3 3 3</small></p> <p>This parameter may be found in Setup/Parameter Database/Controller/System ID.</p>
9.	<p>GIO signals may then be checked under Control Panels/Remote IO/Servo Node 8.</p>

Replacing the Main Harness

Replacement of the Main Robot Harness is typically only performed at the factory. The Main Robot Harness is intended to last for the life of the robot.

Replacing the Outer Link Harness

The Outer Link Harness is composed of three cables: Harness, FFC, J4 Motor, (PF0H-MA-00002-02-E3), Harness, FFC, J4 Encoder (PF0H-MA-00005-02-E3), and Harness, Gripper Controller (PF0H-MA-00014).

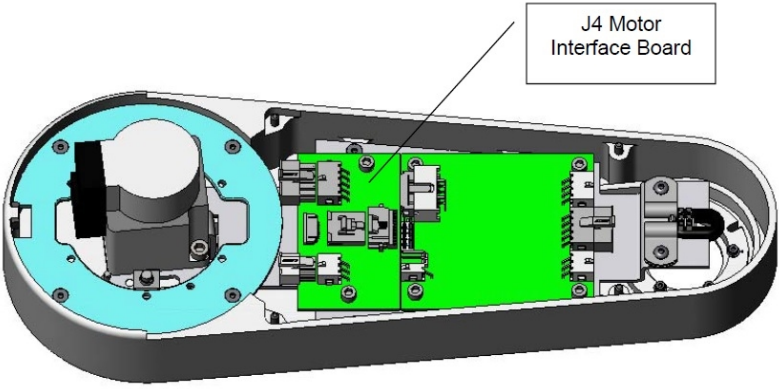

Replacing the Outer Link Harness does not require unmounting the robot from its surface. To replace the Outer Link Harness, perform the following procedure:

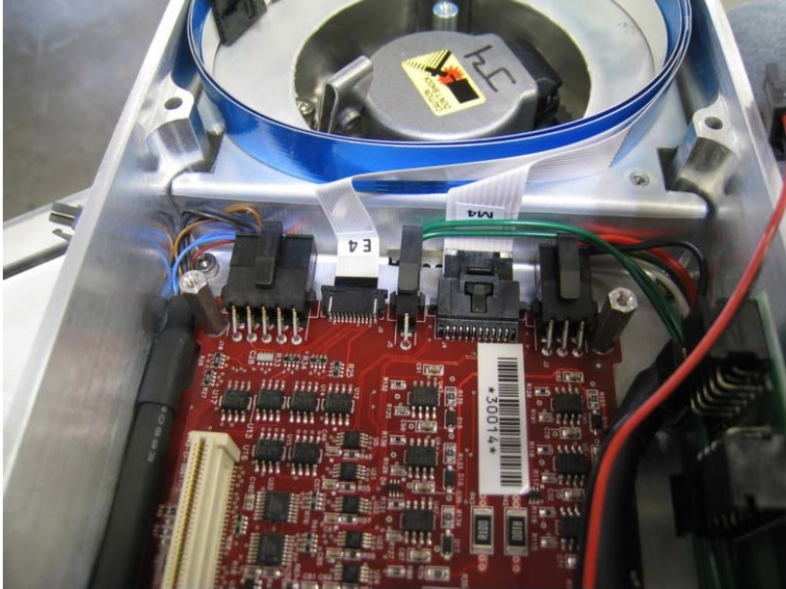
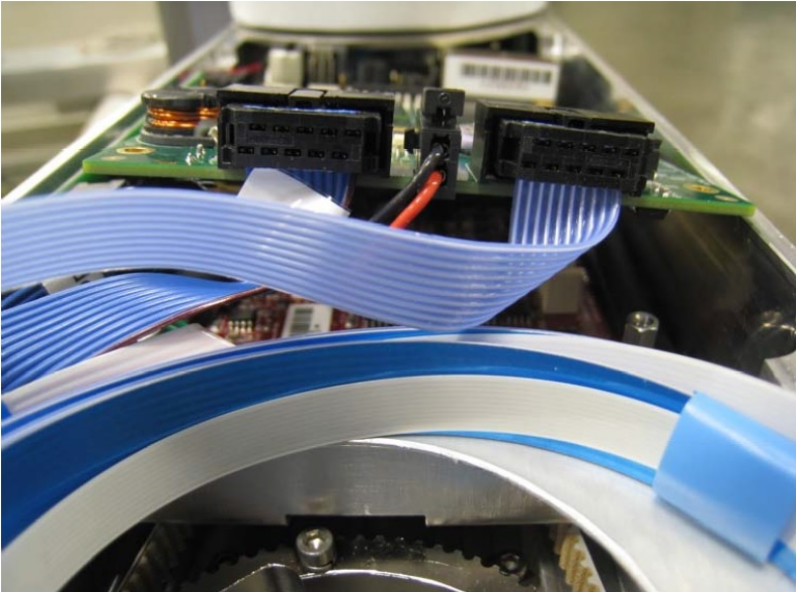
Step	Action
1.	Remove the Inner Link Cover.
2.	Remove the Outer Link Cover.
3.	Unwind the Outer Link in counterclockwise direction, looking down from above the J3 axis until it reaches the hard stop.
4.	<p>Release the J4 Motor Interface circuit board by removing the (2) M3 X 10 mm SHCS.</p> 
5.	Disconnect the Outer Link Harness from the J4 Motor Interface PCA and the Guidance 1100C Slave Controller in the Outer Link.
6.	Remove the upper circuit board in the Robot Controller by removing the (4) M2.5 X 6 mm screws and disconnect the harness.
7.	Remove the Harness Retaining Clip from the Robot Controller Mount Plate to release the controller end of the harness.
8.	Remove the (4) M2.5 X 16 mm standoffs attaching the lower circuit board in the Robot Controller. Gently tip the lower circuit board upwards and disconnect the motor and encoder cables from the lower circuit board.
9.	Release the Harness Retaining Clip from the J3 Output Pulley by loosening the M3 X 25 mm SHCS attaching the clip to the pulley. Pull the clip upwards and remove the M3 X 4 mm BHCS that clamps the harness to release the harness from the clip.
10.	Replicate the folds on the controller end of the replacement harness.

Step	Action
11.	<p>Insert the replacement harness into the Robot Controller circuit boards and reattach the Robot Controller circuit boards.</p>  
12.	Attach the Harness Retaining Clip near the Robot Controller to retain the Robot Controller end of the Harness.
13.	Coil the replacement harness into (3) loops.
14.	Fold the ends of the harness down at a right angle to replicate the replaced harness.

Step	Action
15.	Insert the connectors down thru the Elbow into the Outer Link.
16.	<p>Attach the J3 Harness Retaining Clip with the M3 X 4 mm BHCS and the 1/32 in thick Neoprene rubber strain relief pad around the harness to protect it along with the bent stainless steel retaining clip that protects the harness fold.</p> 
17.	Attach the J3 Harness Retaining Clip to the J3 Output Pulley.
18.	Attach the connectors to the circuit boards in the Outer Link.
19.	Attach the J4 Motor Interface circuit board.
20.	Replace the covers.
21.	After replacing the harness the robot must be re-calibrated. See Calibrating the Robot: Setting the Encoder Zero Positions .

Replacing the Z-axis Motor Assembly

 DANGER Electrical Shock	
<p>Before replacing the Z-axis Motor, the AC power should be removed.</p>	

Tools Required:

- 5.0 mm hex driver or hex L wrench
- 4.0 mm hex driver or hex L wrench
- 3.0 mm hex driver or hex L wrench
- 2.5 mm hex driver or hex L wrench
- Loctite 243

Spare Parts Required:

- J1 Motor Assembly PN PF00-MA-00028

The J1 Motor Assembly is composed of the J1 motor, connectors, and a timing belt pulley.

To replace the Z-axis motor assembly, perform the following procedure:

Step	Action
1.	Remove AC power and connectors from the base of the robot.
2.	Unfasten the robot from its mounting surface by removing the (4) M6 SHCS.
3.	Lay the robot on its back, being careful the robot links do not fall over and damage the paint. It is a good idea to wrap the links with a protective cover first, such as a sheet of foam.
4.	Remove the top cover by removing the (4) M5 Low Head Cap Screws.
5.	Remove the Front Cover by sliding it out.
6.	Remove the left splash guard by removing the M3 X 8 mm SHCS and M3 star washer.
7.	Remove the screws attaching the Electronics Chassis and ground lug to the Bottom Mounting Plate.

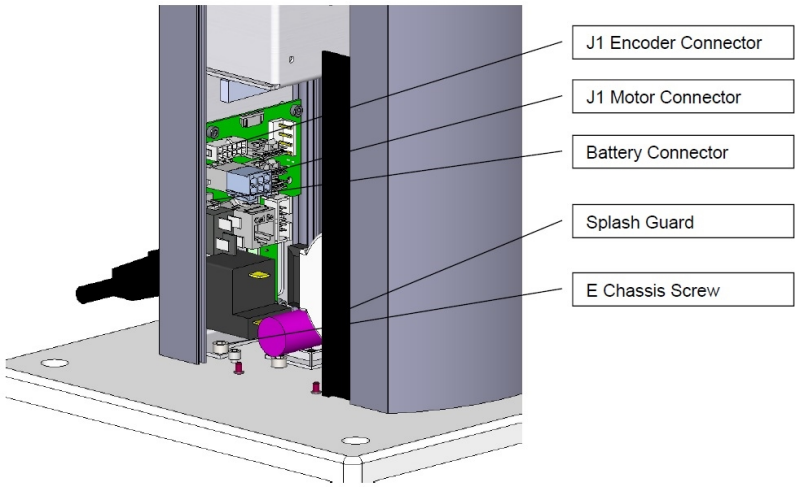
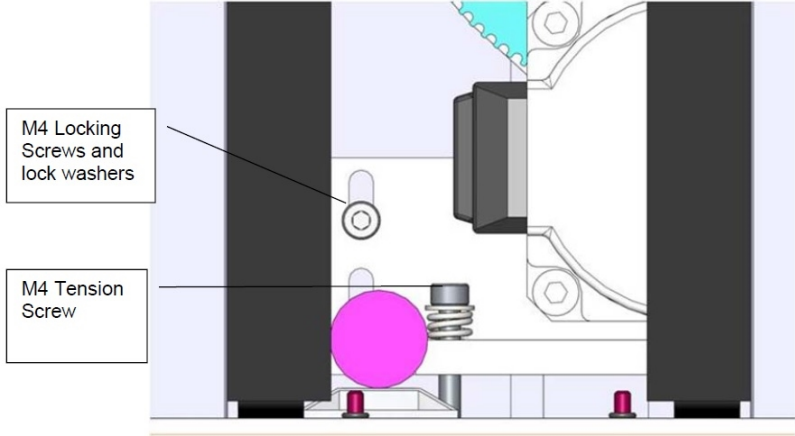
Step	Action
8.	<p>Unplug the Battery from the J1 Motor Interface Board.</p>  <p>The diagram shows a cutaway view of the robot's internal components. A pink motor is highlighted. Callouts point to the following parts: J1 Encoder Connector, J1 Motor Connector, Battery Connector, Splash Guard, and E Chassis Screw.</p>
9.	<p>Remove the screw compressing the J1 Motor Tension Spring and spring.</p>  <p>The diagram shows a close-up of the motor tension spring mechanism. Callouts point to the M4 Locking Screws and lock washers, and the M4 Tension Screw.</p>
10.	<p>Remove the Base Mounting Plate by removing the (4) M5 SHCS. The right splash guard is attached to the base mounting plate.</p>
11.	<p>Remove the M4 Locking Screws that attach the J1 Motor Mount Bracket to the Z Column.</p>
12.	<p>Slide the J1 Stage 1 timing belt off the large idler pulley.</p>
13.	<p>Slide the J1 Motor and Motor Mount Bracket assembly out the bottom of the Z Column.</p>
14.	<p>Remove the J1 Motor Assembly from the J1 Motor Mount Bracket and replace with the new motor, using Loctite 243.</p>

Step	Action
15.	Replace the components in reverse order. Compress the tension spring to 5.5 mm under the washer with the M4 Motor Bracket Locking screws slightly loose, then tighten the screws. Use Loctite 222 or 243 on the Base Plate and Top Plate screws.
16.	Before replacing the Front Cover and Top Plate, the Cal Pins should be removed from inside the Front Cover and the robot should be re-calibrated following the Calibration Procedure in Calibrating the Robot: Setting the Encoder Zero Positions .

Replacing the J2 (Shoulder) Axis Motor or Timing Belt

DANGER
Electrical Shock

<p>Before replacing the J2 Motor, the AC power should be removed.</p>	
---	---

Tools Required:

- 5.0 mm hex driver or hex L wrench
- 4.0 mm hex driver or hex L wrench
- 3.0 mm hex driver or hex L wrench
- 2.5 mm hex driver or hex L wrench
- 2.0 mm hex driver or hex L wrench
- Fine point tweezers
- 0.06 in flat blade screwdriver

Spare Parts Required:

- J2 Motor Assembly (PF02-MA-00011) or J2 Timing Belt (PF00-MC-X0005)
- 2 1/8th by 8 in tie wraps
- Loctite 243

The J2 Motor Assembly is composed of the J2 motor, connectors, and a timing belt pulley. To replace the J2 (shoulder) axis motor or timing belt, perform the following procedure:

Step	Action
1.	Unbolt the robot from its mounting surface and set it vertically on the floor or a low surface.

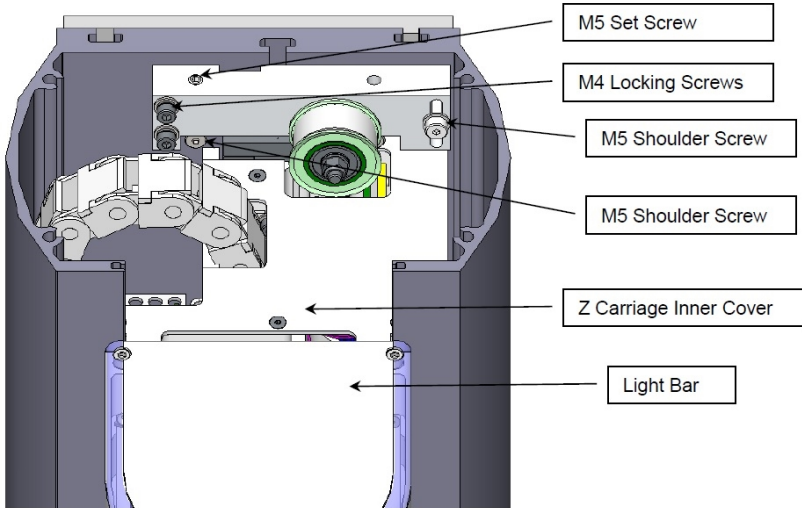

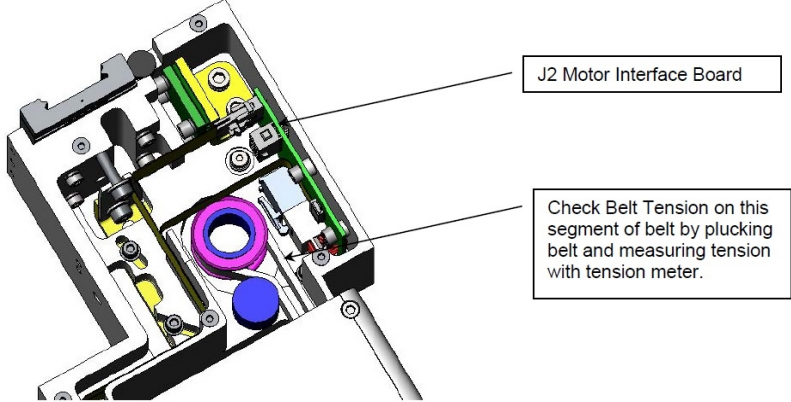
Step	Action
2.	Move the robot arm to about 2 inches below the top of the Z Column travel.
3.	Turn off the robot power and remove the AC power cord.
4.	Remove the Top Plate of the robot by removing the (4) M5 socket head screws from the top plate of the robot that attach the top plate to the Z column.
5.	Remove the Front Cover by lifting it out horizontally.
6.	<p>Remove the Z carriage inner cover by removing the (5) M3 X 10 mm FHCS.</p> 
7.	Remove the Light Bar by removing the (3) M3 X 8 mm SHCS and unplugging the connector from the J2 Motor Interface PCA.
8.	Remove the tie wrap securing the harness loop to the Z carriage.
9.	Remove the M2 and E2 Flat Ribbon Cables from the J2 motor interface board. The E2 connector Cam lid must be VERY gently pried open with a .06 in flat bladed screwdriver.

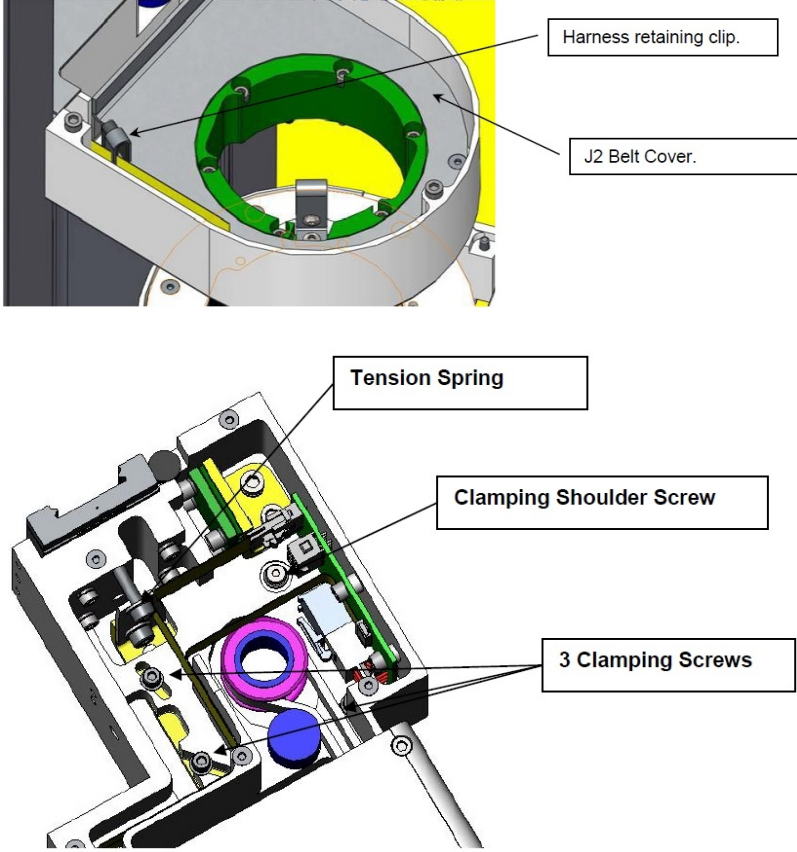
Step	Action
10.	<p>Remove the J2 Motor Interface PCA by removing the (2) M3 X 8 mm SHCS. Cut the tie wrap securing the J2 motor cables to the Z Carriage. Unplug the J2 motor and encoder cable from the J2 Motor Interface PCA.</p> 
11.	Disconnect the harness retaining clip from the Z carriage, but do not remove the clips that attach the harness to the J2 pulley.
12.	Uncoil the harness. One end will remain connected to the E-Chain and the other end will be connected to the J2 Pulley.
13.	Remove the J2 Belt Cover by removing the (3) M3 X 10 mm FHCS, and pull it partially up the uncoiled harness to expose the J2 timing belt.

Step	Action
14.	<p>Unsnap (3) or (4) of the E-Chain harness retaining segments, working up from the carriage, and fold the E-chain and harness back over the power supply side of the robot to get it out of the way.</p> 
15.	Loosen the (3) M3 SHCS and (1) M4 shoulder screw that attach the J2 motor bracket.
16.	Measure and record the distance from the back of the Tension Spring to the carriage, then remove the M4 X 20 mm SHCD and washer that compress the Tension Spring.
17.	Pull the timing belt up over the idler cam follower closest to the large J2 pulley to release belt tension and provide enough slack to remove the motor.
18.	If it is necessary to replace the J2 timing belt, replace the belt and reassemble the robot. Otherwise, skip this step and continue on to Step 19.
19.	Loosen the (4) screws and washers that attach the motor mount plate to the Z carriage while supporting the motor. It may be easiest to leave these screws in the carriage during this process.
20.	Drop the motor assembly downwards while threading the motor cables through the access hole in the bottom of the Z carriage, and pulling the timing belt up over the pulley flange.
21.	Remove the motor from the Motor Mount Bracket by removing the (4) M5 X 12 mm SHCS. Attach the new motor to the Motor Mount Bracket using Loctite 243.

Step	Action
22.	Re-install motor, threading cables through the Z carriage first, and pulling timing belt over pulley flange. Attach motor with (4) clamping screws. Do not tighten clamping screws all the way.
23.	Re-install the M4 X 20 mm Tension Bolt and compress the Tension Spring to the previous value. Tighten the M4 Jam nut to lock the bolt and Tension Spring. This will cause motor assembly to pivot on the shoulder screw and will apply tension to the timing belt. Before tightening the clamping screws, rotate the J2 output pulley back and forth to ensure that the timing belt is running true on the output pulley.
24.	Tighten the clamping screws. If a Tension Meter is available check the belt tension for a minimum tension of 150N. (See Appendix E: Belt Tensions, Gates Tension Meter).
25.	Re-assemble the robot except for the front cover and top cover.
26.	Remove the Calibration Pins from the inside of the front cover extrusion and re-calibrate the robot following the Calibration Procedure in Calibrating the Robot: Setting the Encoder Zero Positions .

Replacing the J3 (Elbow) Axis Motor or Timing Belt

 DANGER Electrical Shock	
Before replacing this motor, the AC power should be removed.	

Tools Required:

- 3.0 mm hex driver or hex L wrench
- 2.5 mm hex driver or hex L wrench
- 2.0 mm hex driver or hex L wrench
- Fine point tweezers
- 0.06 in flat blade screwdriver

Spare Parts Required:

- J3 Motor Assembly (PF03-MA-00011) or J3 Timing Belt (PF00-MC-X0003)
- 2 1/8th by 8 in tie wraps
- Loctite 222 and 243

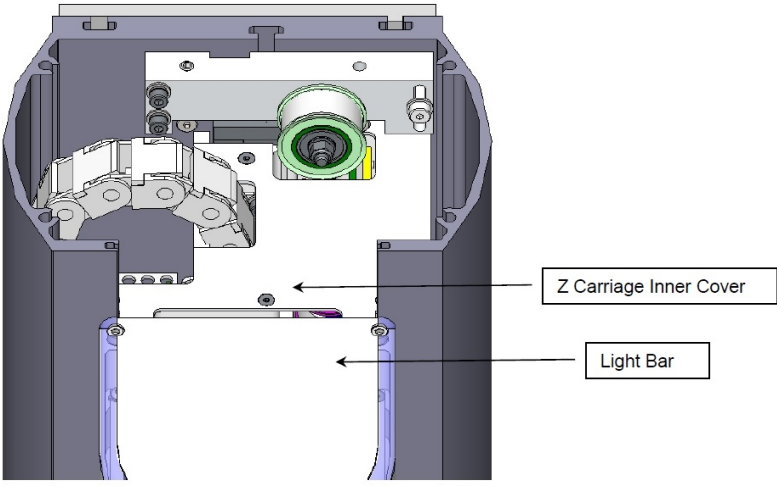

The J3 Motor Assembly is composed of the J3 motor, connectors, and a timing belt pulley. To replace the J3 (elbow) axis motor or timing belt, perform the following procedure:

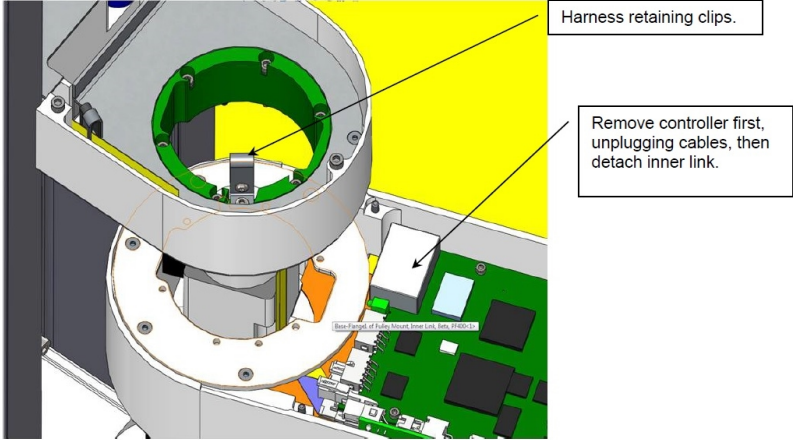
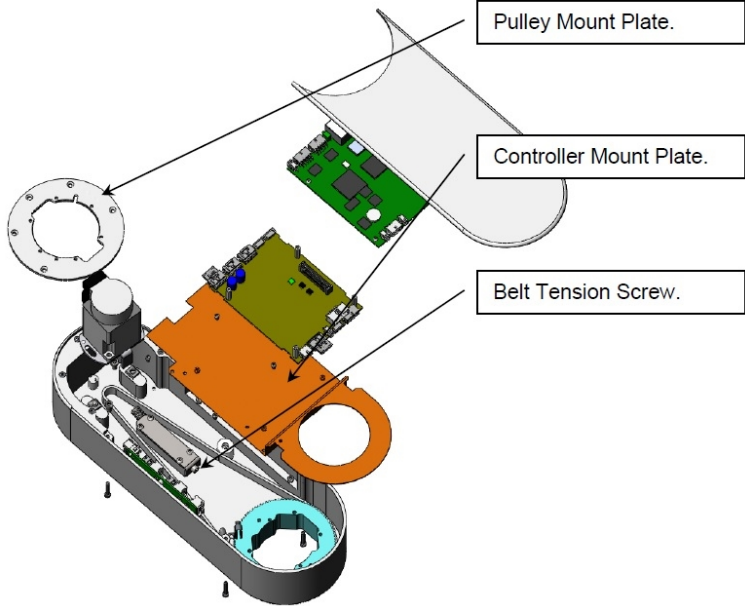
Step	Action
1.	Unbolt the robot from its mounting surface and set it vertically on the floor or a low surface.
2.	Move the robot arm to about 2 inches below the top of the Z Column travel.
3.	Turn off the robot power and remove the AC power cord.
4.	Remove the Top Plate of the robot by removing the (4) M5 socket head screws from the top plate of the robot that attach the top plate to the Z column.
5.	Remove the Front Cover by lifting it out horizontally.
6.	<p>Remove the Z carriage inner cover by removing the (5) M3 X 10 mm FHCS.</p> 
7.	Remove the Light Bar by removing the (3) M3 X 8 mm SHCS and unplugging the connector from the J2 Motor Interface PCA.
8.	Remove the controller from inner link.

Step	Action
9.	<p>Detach the inner link from the Z carriage by removing the (6) M3 X 35 mm SHCS and lock washers.</p> 
10.	<p>Remove round Pulley Mount Plate from the Inner Link by removing the (5) M3 FHCS.</p>
11.	<p>Remove the J3 Controller Mount Plate from the Inner link by removing the (4) M3 X 5 mm SHCS.</p> 
12.	<p>Remove the J3 motor by removing the (2) M4 screws that attach the motor to the motor mount plate, and rotate the motor up and out of the motor mount plate. This procedure will preserve the belt tension and avoid having to use a tension meter to reset the belt tension, as it preserves the position of the motor mount plate.</p>

Step	Action
13.	Replace the J3 motor, using Loctite 243, or optionally, replace the J3 timing belt if necessary. Since the motor mount plate has not been removed, the belt tension should not need to be adjusted.
14.	If a Belt Tension Meter is available, check the belt tension per Appendix E: Belt Tensions, Gates Tension Meter . Check the belt tension every 10 degrees of rotation of the J3 output pulley and set the belt tension at its lowest point to the minimum value in Appendix E: Belt Tensions, Gates Tension Meter .
15.	Replace the pulley mount plate using Loctite 222 and re-assemble the robot.
16.	Re-calibrate the robot.

Replacing the J4 (Wrist) Axis Motor or Timing Belt

 DANGER Electrical Shock	
<p>Before replacing this motor, the AC power should be removed.</p>	

Tools Required:

- 3.0 mm hex driver or hex L wrench
- 2.5 mm hex driver or hex L wrench
- 2.0 mm hex driver or hex L wrench
- Fine point tweezers
- 0.06 in flat blade screwdriver

Spare Parts Required:

- J4 Motor Assembly (PF04-MA-00011) or J4 Timing Belt (PF00-MC-X0004)
- Loctite 222 and 243

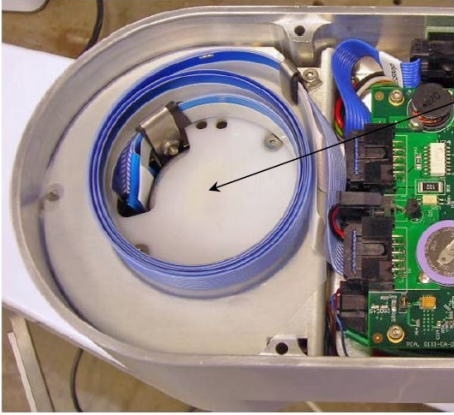

The J4 Motor Assembly is composed of the J4 motor, connectors, and a timing belt pulley. To replace the J4 (Wrist) Axis Motor or Timing Belt, perform the following procedure:

Step	Action
1.	Move the robot arm to a convenient height on the Z column for removing the outer link.

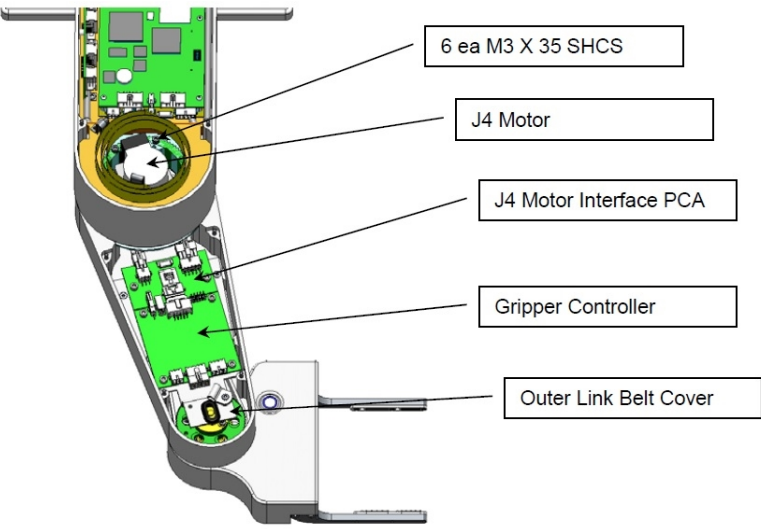
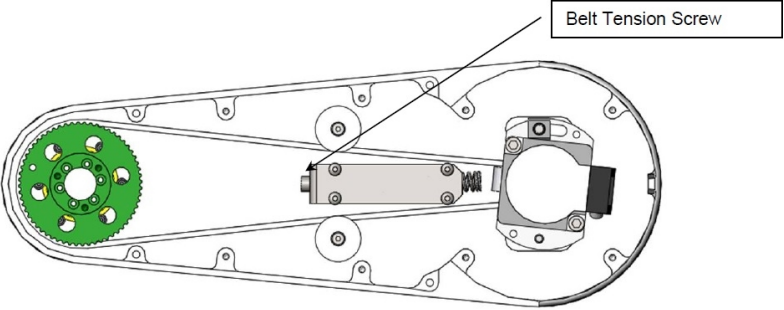
Step	Action
2.	Turn off the robot power and remove the AC power cord.
3.	Remove the inner link cover by removing the (4) M3 X 20 mm SHCS and lock washers.
4.	Remove the outer link cover by removing (4) M3 X 20 mm SHCS and lock washers.
5.	<p>Remove the J4 Motor Cover in the Elbow by removing the (2) M3 X 10 mm FHCS.</p> 
6.	Rotate the Outer Link clockwise (viewing from above) until it hits the hard stop. This will expand the harness coil and the link will be position as shown below, about 10 degrees from straight out.
7.	Remove the J4 Motor Interface Board in the Outer Link and unplug the cables.
8.	Remove the Outer Link by removing the (6) M3 X 35 mm SHCS in the J3 Output Pulley that attach the Outer Link.
9.	Remove the Gripper Controller by unplugging the Gripper harness and removing the (4) M3 X 8 mm SHCS.

Step	Action
10.	<p>Remove the Outer Link Belt Cover by removing the (4) M3 X 10 mm SHCS.</p> 
11.	<p>Remove the J4 motor by removing the (2) M4 screws attaching the motor to the motor mount plate, and rotate the motor up and out of the motor mount plate. This procedure will preserve the belt tension and avoid having to use a tension meter to reset the belt tension, as it preserves the position of the motor mount plate.</p>
12.	<p>Replace the J4 motor, using Loctite 243, or optionally, replace the J4 timing belt if necessary. Since the motor mount plate has not been removed, the belt tension should not need to be adjusted.</p>
13.	<p>If a Belt Tension Meter is available, check the belt tension per Appendix E: Belt Tensions, Gates Tension Meter. Check the belt tension every 10 degrees of rotation of the J4 output pulley and set the belt tension at its lowest point to the minimum value in Appendix E: Belt Tensions, Gates Tension Meter.</p>
14.	<p>Replace the pulley mount plate using Loctite 222 and re-assemble the robot, with the outer link positioned as shown in Step 10 so that the link is correctly oriented with respect to the hard stop.</p>
15.	<p>Re-calibrate the robot.</p> 

Replacing Servo Gripper with Pneumatic or Vacuum Gripper

 DANGER Electrical Shock	
Before replacing this motor, the AC power should be removed.	

Tools Required:

- 3.0 mm hex driver or hex L wrench
- 2.5 mm hex driver or hex L wrench
- 2.0 mm hex driver or hex L wrench
- 1.3 mm hex driver of hex L wrench
- Fine point tweezers
- 0.06 in flat blade screwdriver

Spare Parts Required:

- Pneumatic or Vacuum Gripper and installation kit, including air harness for elbow, 10 conductor ribbon cable for IO harness, barbed plastic air fittings, and metal retaining clip for air hose in J4 pulley, and vacuum/j4 motor interface board to replace standard J4 motor interface board for robots older than Revision C (2016).

The user will need to get different PAC files from PreciseFlex as one servo axis is deleted.



This modification should only be performed by a trained service technician. It requires a robot that has an air line pre-installed at the factory. Some robots with servo grippers built after April 2014 have this feature. If the air line is installed, a pneumatic fitting will be installed on the robot connector panel.

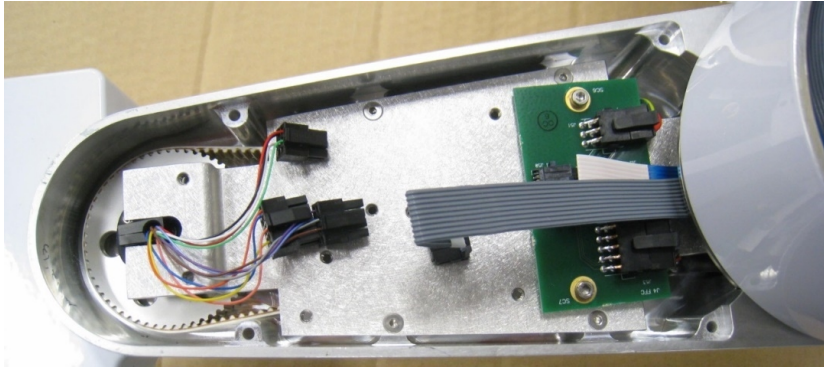
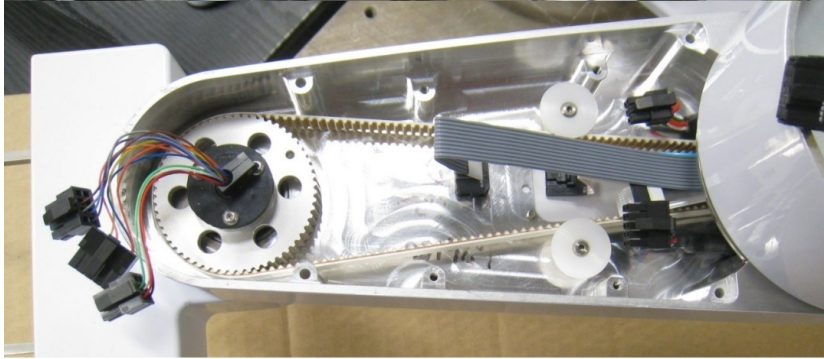

To replace the Servo Gripper with Pneumatic or Vacuum Gripper, perform the following procedure:

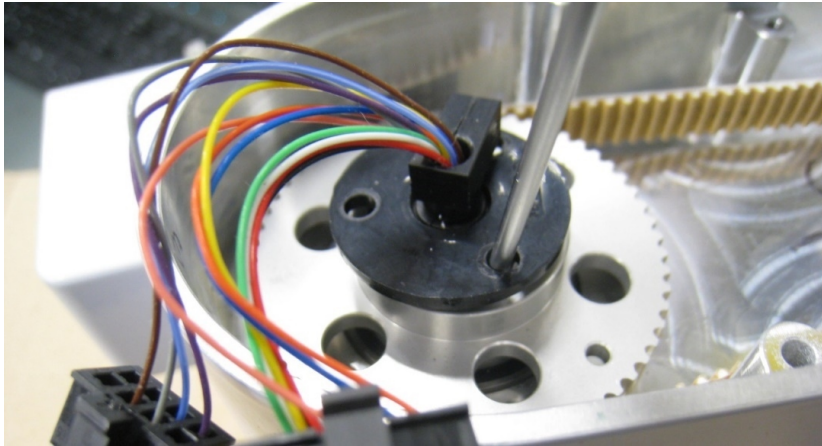

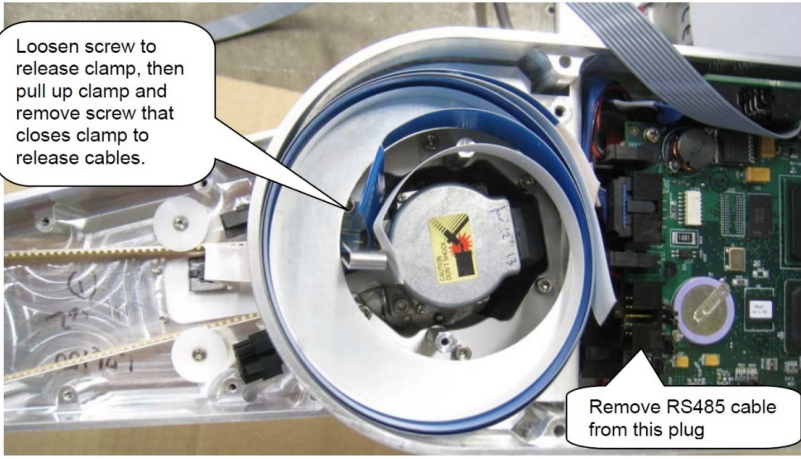
Step	Action
1.	Move the robot arm to a convenient height on the Z column for removing the servo gripper.
2.	Turn off the robot power and remove the AC power cord.
3.	Remove the inner link cover by removing the (4) M3 X 20 mm SHCS and lock washers.
4.	Remove the outer link cover by removing the (4) M3 X 20 mm SHCS and lock washers.

Step	Action
5.	<p>Remove the gripper controller (GSB) by removing the (4) M3 X 8 mm SHCS.</p> 
6.	<p>Remove the FFC to motor cable interface board and sheet metal belt cover in the outer link.</p> 
7.	<p>Remove the bottom cover from the gripper.</p>
8.	<p>Remove the (3) M3 BHCS that retain the slip ring.</p> <p>NOTE: Do not try to remove slip ring yet.</p>

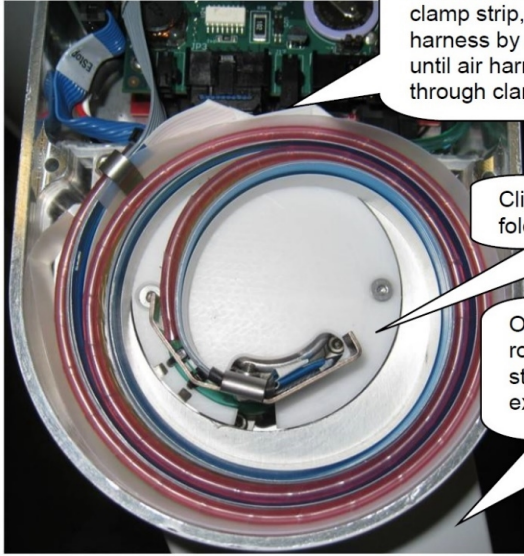
Step	Action
9.	<p>Unplug the slip ring connectors inside the servo gripper.</p> 
10.	<p>Rotate the slip ring slightly to expose the M2 counter bores in the J4 output pulley. Using a M1.5 hex driver, remove the (6) M2 X 16 mm SHCS that attach the gripper. Lower the gripper gently while feeding the slip ring connectors through the hole in the gripper housing.</p> 
11.	<p>Remove the slip ring.</p>
12.	<p>Loosen the M3 screw that attaches the harness cable clamp to the J3 output pulley until the clamp can be pulled all the way up to provide access to the M3 X 8 mm BHCS that closes the clamp. Remove this screw and the rubber pad on the harness.</p>

Step	Action
13.	<p>Remove the RS-485 10 conductor ribbon cable from the robot by feeding the connector up past the J4 motor in the outer link, removing this cable from the retaining clamps, and unplugging it from the RS-485 connector in the controller.</p> 
14.	<p>Plug IO cable for pneumatic gripper option into IO connector on side of inner link.</p> 

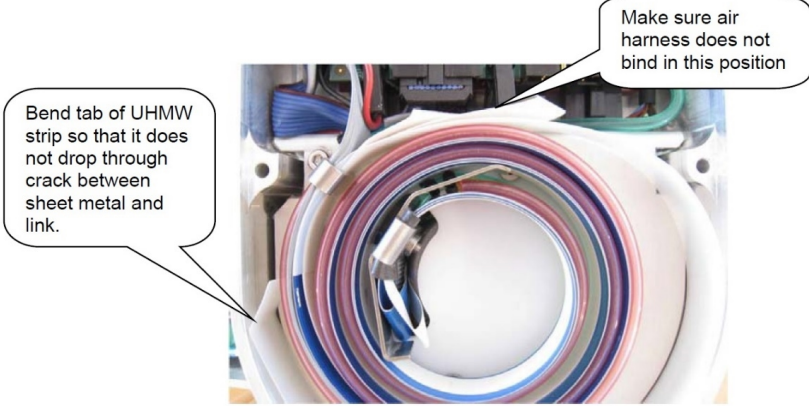
Step	Action
15.	<p>Add air harness along with IO harness and clamp as shown, after routing cables back down to outer link. Note the order of folds in the cables. The white encoder cable should be on the inside, then the blue shielded motor cable, and then the IO 10 conductor ribbon cable.</p>  <p>Add .010 in UHMW strip and clamp strip, wire harness and air harness by squeezing this clamp until air harness does not slip through clamp.</p> <p>Clip to protect harness fold, added mid-2014.</p> <p>Outer link has been rotated clockwise to hard stop and harness is fully expanded.</p>
16.	<p>Add a tie wrap to the harness tube to prevent the harness from slipping through the clamp.</p> 
17.	<p>Route the air tube under the IO cable and connect it to the air tube in the inner link with the plastic barbed connector.</p>

Step	Action
18.	<p data-bbox="321 279 1349 363">Bend the rotating metal clip inwards towards the motor as far as possible. Rotate the outer link and check that the air harness does not bind on the controller connectors as the rotating clip passes the controller.</p>  <p data-bbox="326 499 537 642">Bend tab of UHMW strip so that it does not drop through crack between sheet metal and link.</p> <p data-bbox="927 405 1130 478">Make sure air harness does not bind in this position</p>
19.	<p data-bbox="321 852 1333 905">Check the harness when the outer link is fully rotated counter-clockwise to ensure that there is no binding.</p> 

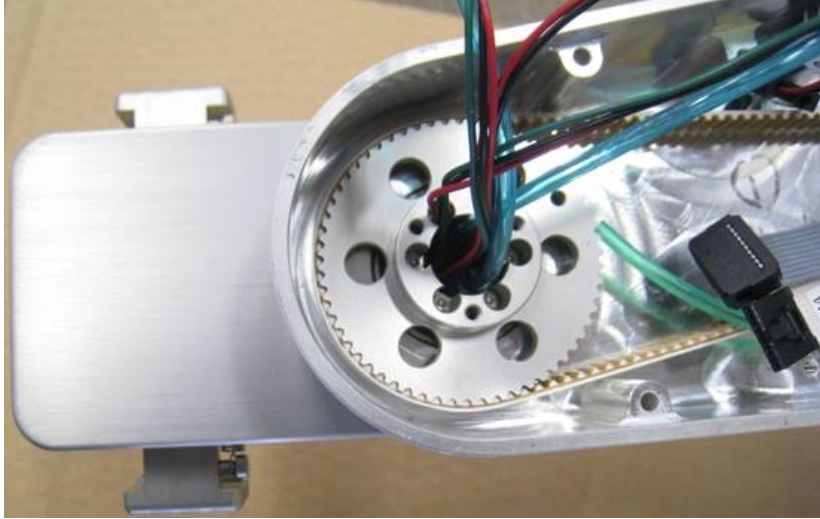
Step	Action
20.	<p data-bbox="321 268 1383 331">Install the Delrin bumper for sliding stop in the threaded hole under the end of the outer link with 4-40 X 3/8 mm Steel Socket Head Cap Screw and Loctite 222.</p> 
21.	<p data-bbox="321 814 1383 903">Add the slider for pneumatic or vacuum gripper to the top of the gripper and attach the gripper to the J4 output pulley by tightening the (6) M2 SHCS after threading the wires and hoses from the gripper through the pulley.</p> <p data-bbox="321 928 1286 987">Ensure that the dowel pin in the J4 pulley fits into the notch in the gripper to orient the gripper. Be very careful not to pinch any wire between the gripper and the pulley.</p> 

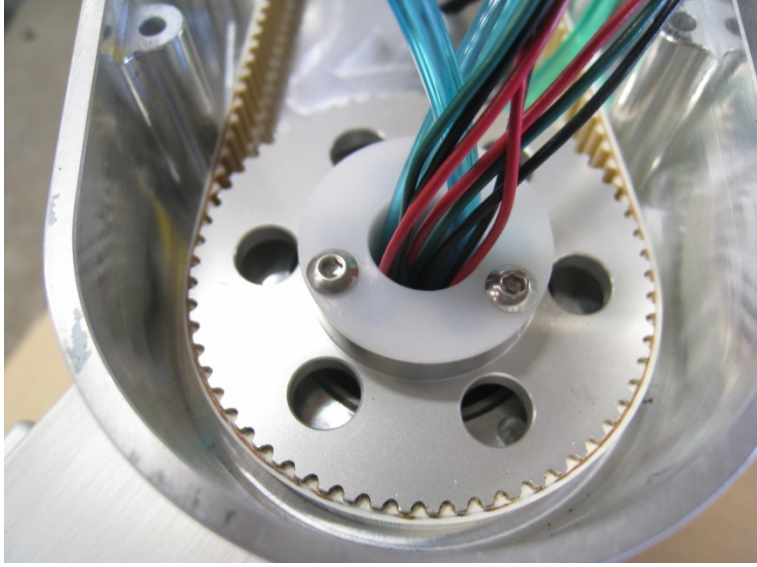
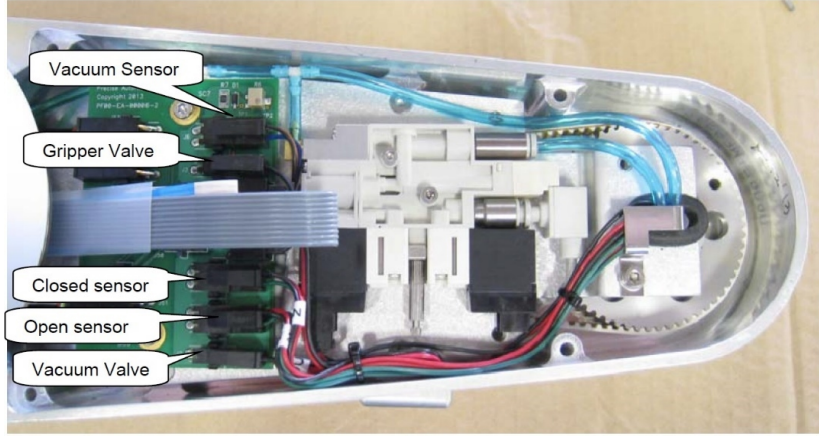
Step	Action
22.	<p>Thread the wires and hoses through the white plastic bushing and install the bushing into the pulley with (3) M3 BHCS.</p> 
23.	<p>Replace the outer link sheet metal belt cover by sliding under the cables from the motor and inner link, but do not install the screws yet.</p>
24.	<p>Install the vacuum generator as shown for the vacuum-pallet gripper and for the vacuum gripper. For the vacuum-pallet gripper, the vacuum gripper, and the pneumatic gripper, rotate the gripper until it is centered under outer link. Then stretch the rubber grommet over the wires and hoses and slide the grommet into the sheet metal belt cover so that the wires are on the inside of any hoses.</p> <p>NOTE: Ensure that the wires are not twisted around the hoses. Ensure that the gripper can rotate 270 degrees in both directions without putting any strain on the wires. If the wires are pulled by the rotation of the gripper, they will eventually fail.</p> 

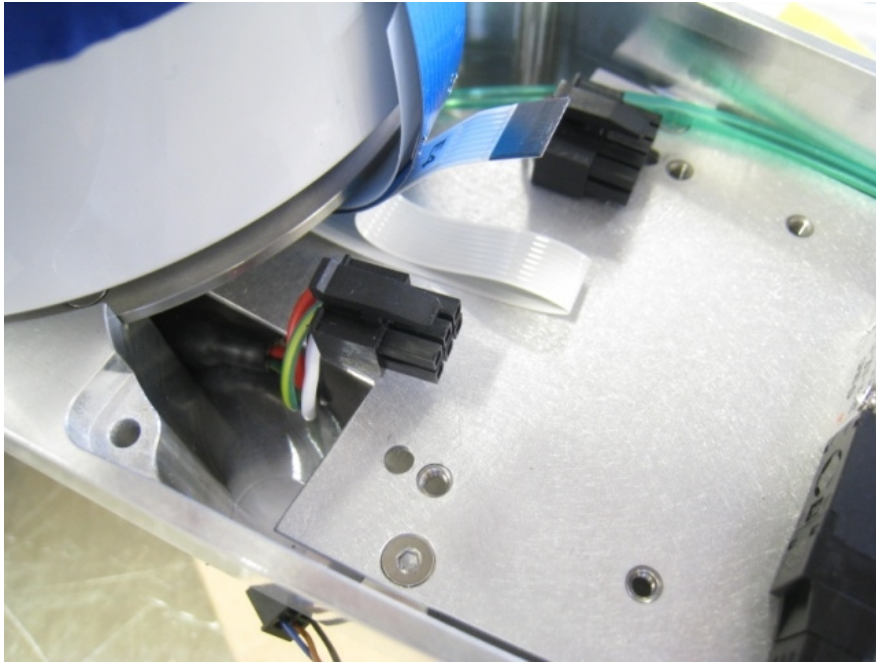

Table 2-1: Wiring & Fold Detail for Interface Board

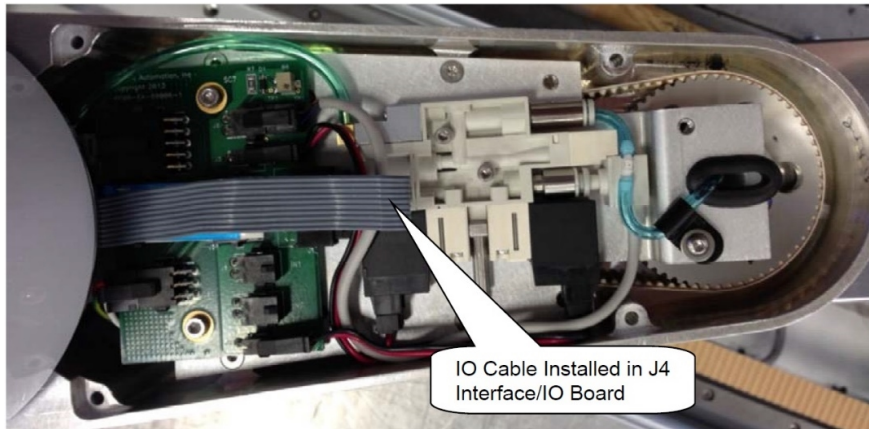

Figure 2-10: Vacuum Gripper Configuration with Vacuum Interface Board

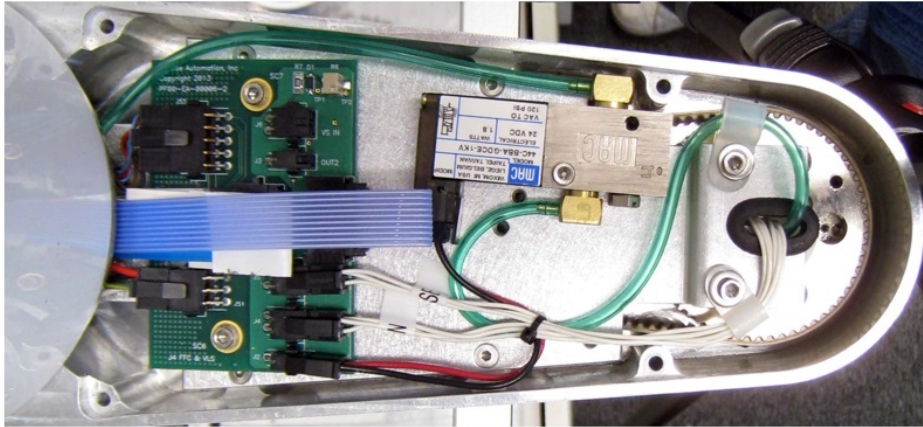

Figure 2-11: Pneumatic Gripper Configuration



Figure 2-12: Dual Pneumatic Gripper Configuration (with Rev C Sheet Metal, 2016)

Step	Action
1.	<p>After installing the appropriate gripper, check Digital Input 1 for the Pneumatic Gripper open sensor, Digital Input 2 for the Pneumatic Gripper close sensor, and Digital Input 4 for the vacuum present sense, if these sensors are installed.</p> <p>For Vacuum Grippers, Digital Output 1 will turn on the vacuum valve and Digital Output 2 will turn on the vacuum blow-off function in the vacuum generator, if installed.</p> <p>For Pneumatic Grippers, Digital Output 1 turns on the pneumatic valve 1 and Digital Output 2 turns on the pneumatic valve 2.</p>

Step	Action
2.	<p>After removing the servo gripper, install the new PAC files in the robot to correctly configure it as a 4-axis robot, or 4-axis robot on a linear rail. Unless the correct PAC files are installed, the software will be looking for the missing gripper controller (GSB) and will generate an error.</p> <p>See Updating GPL (System Software) or FPGA (Firmware).</p>
3.	<p>After the new PAC files are installed, or after unplugging the J4 motor/encoder interface board, the robot must be re-calibrated.</p> <p>See Calibrating the Robot: Setting the Encoder Zero Positions.</p>

Appendices

Appendix A: Product Specifications

General Specification	Range
PERFORMANCE	
Payload	0.5 kg including the Servo Gripper
Typical Speed at TCP	500 mm/sec
Max Acceleration	2000 mm/sec ²
Repeatability	±0.090 mm
RANGE OF MOTION	
Joint 1 (Z-axis)	400, 750, 1160 mm
Joint 2	±93°
Joint 3	±168°
Joint 4	±960° with servo gripper
Horizontal Reach	579 mm, standard reach 734 mm, extended reach
COMMUNICATIONS	
General	100 Mb Ethernet, TCP/IP EtherNet/IP
Operator Interface	Web-based operator interface
Digital I/O	12 inputs, 8 outputs at base of robot optically isolated, 24 V @ 100 ma 2 in, 4 out for end-of-arm-tooling Remote I/O available
FACILITIES	
Power	90 to 264 VAC, auto selecting 50-60 Hz 100-250 watts typical operation
Controller Mounting	Embedded into robot base
Air Lines	Two, 3.2 mm OD, 1.6 mm ID, max pressure 500 kpa (75 psi)
Weight	Standard Reach/Extended Reach 20 kg/25 kg (400 mm Z-axis) 25 kg/30 kg (750 mm Z-axis) 30 kg/35 kg (1160 mm Z-axis)
SOFTWARE	
Programming	Guidance Motion (web interface) Guidance Programming Language (GPL) TCP Command Server (TCS)

General Specification	Range
Enhanced Functions	Hand Guiding (standard) Horizontal Compensation Z-Height Detection
PERIPHERALS AND ACCESSORIES	
General	23 N Servo Gripper Gripper Fingers for SBS plates, tubes, vials... Remote I/O (RIO)
Linear Rail	1.0, 1.5, and 2.0 M travel Speed up to 750 mm/sec Repeatability: ±0.05 mm
Vision	IntelliGuide Vision Gripper, 23 N

Appendix B: Environmental Specifications

NOTE: Our PreciseFlex robots are powered by 24 VDC and 48 VDC low-voltage DC power supplies with built-in overcurrent protection. For this reason, the PreciseFlex robots do not have an SCCR.

The PreciseFlex Robots must be installed in a clean, non-condensing environment with the following specifications:

Table 2-2: Environmental Specifications

General Specification	Range & Features
Ambient temperature	4° C to 40° C
Indoor use only	
Storage and shipment temperature	-25° C to +55° C
Humidity range	10 to 55%, non-condensing, non-corrosive
Altitude	Up to 3000 m
Voltage	100-240 VAC +/- 10%, 50/60 Hz
Mains cord rating, min	18 AWG, 3 conductor, 5 Amps min
Pollution Degree	2
Approved Cleaning Agents	IPA, 70% Ethanol/30% water, H2O2 Vapor up to 1000 ppm
IP rating	11
IK impact rating	IK08: 5 Joule

Appendix C: Spare Parts List

NOTE: Email support_preciseflex@brooksautomation.com for help replacing spare parts.

The part number format is:

- F0v-wwww-xy-zzzzz
- v - Major version - "X" for rev A; "B" for rev B; "C" for rev C
- wwww - Ship date,yyymm, so 1207 means July 2012
- x is the controller rev
- y is the robot rev
- zzzzz - is a unique robot number.

Table 2-3: Spare Parts List

Description	Part Number	Rev C PN
Absolute Encoder Battery Assembly	PF0H-MA-00057	
J1 Motor Assembly	PF00-MA-00028	
J1 Stage 1 Belt	PF00-MC-X0021	
J1 Stage 2 Belt 400 mm	PF00-MC-X0022	
J1 Stage 2 Belt 750 mm	PF00-MC-X0023	
J2 200 W Motor Assembly 9 mm Pulley (Rev A)	PF02-MA-00009	
J2 200 W Motor Assembly 12 mm Pulley (Rev B, C)	PF00-MA-00029	
J2 Belt 12 mm wide (Rev B, C)	PF00-MC-X0081	
J2 Cam Follower for 12 mm belt (set of 2) (Rev B)	PF00-MA-00024	
J2 Cam Follower for 12 mm belt (set of 2) (Rev C)	PF00-MA-00062	Thrust Washers
J3 Motor Assembly	PF00-MA-00030	
J3 Belt - Standard Reach	PF00-MC-X0035	
J3 Belt - Extended Reach	PF00-MC-X0066	
J4 30 W Motor Assembly	PF00-MA-00031	
J4 Belt for Standard Reach	PF00-MC-X0004	
J4 Belt for Extended Reach	PF00-MC-X0065	
PF400 23 N Servo Gripper with Spring, without fingers	G1X0-EA-B1400-12A	
PF400 23 N Servo Gripper with Brake, without fingers	PF00-MA-00115	
Finger Claw Assembly - 23 N servo gripper fingers	PF0S-MA-00010	
G1400B Controller with advanced kinematics license	G1XF-EA-B1400-12A	
G1100T Slave Controller ("GSB3-SE") for Gripper	G1X0-EA-T1101-4	
G1100T Slave Controller ("GSB3-DIFF") for Rail	G1X0-EA-T1101-4D	
GIO Digital IO Board with pigtails	GIO1-EA-01102	
24 VDC Supply	PS10-EP-24150	
48 VDC Motor Supply	PS10-EP-48400	
Slip Ring Harness Assembly, 23 N Brake Gripper	PF04-MA-00002-E8	18Wire
Slip Ring Harness Assembly, 23 N Spring Gripper	397515	18Wire
Harness, FFC, J4 Motor	PF0H-MA-00002-02	

Description	Part Number	Rev C PN
Harness, FFC, J4 Encoder	PF0H-MA-00020-2	
Harness, Gripper Controller	PF0H-MA-00014	
J1 Motor Interface PCA	PF00-EA-00034	New
J2 Motor Interface PCA	PF00-EA-00030	
MIDS Interface PCA	PF00-EA-00035	
J4 Motor Interface PCA	PF00-EA-00036	New

Appendix D: Preventative Maintenance

For help with preventative maintenance, addressing error codes, or any other issue, contact support_preciseflex@brooksautomation.com.

Every one to two years, the following preventative maintenance procedures should be performed. For robots that are continuously moving 24 hours per day, 7 days a week at moderate to high speeds, a one-year schedule is recommended. For robots with low duty cycles and low to moderate speeds, these procedures should be performed at least once every two years.

Table 2-4: Preventative Maintenance, Checklist & Procedures

Check List	Procedure If Problem Detected
Check all belt tensions	Re-tension if necessary
Check air harness tubing in elbow if present, and theta axis for any wear	Replace if necessary
Replace timing belt in optional linear axis	Typically every 6,000 hours of continuous operation
Check all joints in "free mode" for low bearing friction and any sticking.	If a bearing is getting stiff, return to factory for bearing replacement.
Check second stage (long) Z belt for any squeaking	If noisy, add thick grease to front and rear edge of belt if necessary. (Shell 222 XP or similar). Z timing belt can get stiffer over time (2-3 years) and occasionally start squeaking against pulley flanges.
Check if front cover is rattling	If so, check .125in ID by .062in thick O rings on dowel pins in base plate under front cover for any deterioration and replace if necessary.
Check Cam Followers on J2 timing belt for grease leaking or discoloration.	Replace if necessary. Note that earlier units had a 9 mm wide timing belt and later units (2014, 2015) have a 12 mm wide timing and the Cam Followers are different. See Appendix C: Spare Parts List .
Replace slip ring	For units with electric gripper shipped before April 2015, replace the slip ring. For units shipped after April 2015, replace the slip ring every third inspection test.

Table 2-5: PF400 PM Schedule by Revision Level & Date

Component	Expected Life	Action
Revision A, Serial Numbers F0X...		
Slip ring	1-3 years	Replace component
Ethernet cable (flat black Startech)	2-4 years	Replace component
J2 timing belt (9 mm)	2 years	Replace component
Motors with pulleys (bonded)	2-10 years	Replace assembly if bond broken
Harness (any FFC cables)	4-10 years	Replace robot*
Revision B, Serial Numbers F0B...		
Slip ring	3-5 years	Replace component
Ethernet cable (flat black Startech)	2-4 years	Replace component
Revision C, Serial Numbers F0C...		

Component	Expected Life	Action
Slip ring	3-5 years	Replace component
J2 timing belt	5 years heavy use	Replace component
Ethernet cable (flat black Startech before Nov 2017)	2-4 years	Teflon replacement 10 years

NOTE: *Because of EOL parts, this repair requires the replacement of a large amount of electronics and harnessing. Replacing the robot may be more cost effective.

Table 2-6: Linear Axis PM Schedule

Component	Expected Life	Action
Revision A, Serial Numbers FXX...		
Timing belt	6,000 hours/duty cycle*	Replace component
E-chain harnessing	2-4 years	Replace all cables
Ethernet cable	2-4 years	Replace component
Tape seals	2-4 years	Replace component
Tape seal rollers	2-4 years	Replace component
Revision B Feb 2015, Serial Numbers FXB...		
Timing belt	6,000 hours/duty cycle*	Replace component
E-chain harnessing	20,000 hours	Replace all cables
Ethernet cable before May 2017	2-4 years	Teflon replacement 10 years

*For example, if rail operates at 50% duty cycle, expected life is 12,000 hours

Appendix E: Belt Tensions, Gates Tension Meter

In some cases it may be desirable to confirm the belt tension of one of the axes in the robot. This is not normally required, as the robot has been designed with spring tensioners that only require loosening and then re-tightening some clamping screws to reset the belt tensions. However, in the case of the long Z column belts it is possible that after several years of operation, the belt may stretch enough that the tension spring pre-load screw may need to be adjusted. If it appears a belt tension is not being adjusted properly by the pre-load spring, the tension can be checked with a Gates Sonic Tension Meter, Model 507C or 508C ([Figure 2-13](#)).



Figure 2-13: Gates Sonic Tension Meter

To use the tension meter

1. Turn on the power.
2. Click the **Mass** button and enter the belt mass from the table below.
3. Click the **Width** button and enter the belt width from the table below.

4. Click the **Span** button and enter the belt free span from the table below.
5. Click **Select** to record the data.
6. Click **Measure** to take a tension reading.
7. Place the microphone near the belt, typically within 3 mm or so. Gently pluck the belt so that it vibrates. The tension meter will calculate the belt tension from the acoustic vibrations and display the tension in Newtons. Compare the tension to [Table 2-7](#). Adjust the belt tension preload screws if necessary.

Table 2-7: Belt Tension

Belt	Mass (g)	Width (mm)	Span (mm)	Tension (N)
S2 - 400	4.1	12	530	100-130
S2 - 750	4.1	12	880	100-130
S2 - 1160	4.1	12	1290	100-130
J2 - 12mm	2.8	12	108	160-200
J3 - STD/ EXT	2.8	12	113	90-120
J4 - STD	2.8	9	95	45-70
J4 - EXT	2.8	9	146	65-80

NOTE: SDT denotes standard reach and EXT denotes extended reach robots.

Table 2-8: Linear Rail Belt Tension Values

Mass (g)	Width (mm)	Span (mm)	Tension (N)
4.1	20	500	135-160

Appendix F: Example Performance Level Evaluation

Example Workcell Description

A PF400 Plate Handler moves 80 gram plastic trays from storage racks to an instrument and back to the storage racks. Gripper is an electric parallel jaw gripper with maximum 23 N of gripping force for plastic trays and is spring loaded so it will not drop trays if power fails. Robot motion is programmed with approach point 50 mm above the instrument tray and final motion into instrument is made at 50 mm/sec. Lowest storage rack position is 50 mm above table surface. See the example workcell below in [Figure 2-14](#).



Figure 2-14: Example PF400 Workcell, Courtesy of Biosero

Normal Operator Interaction with Robot

Teaching locations in workcell by hand guiding or teach pendant. Maximum robot forces under manual control from PF400 Table 1 are 60 N. Pausing robot and removing racks from workcell with no safety interlocks in workspace. Robot is stopped.

Possible Low Frequency (rare) Interaction with Robot

Untrained operator reaches into workcell while robot is moving and robot collides with operator. Maximum free space collision force from PF400 Table 1 is 80 N. Untrained operator reaches into workcell while robot is moving into instrument tray and hand is trapped between robot and instrument tray. From PF400 Table 1 max trapping force in downwards Z direction at 50 mm/sec (10% of max speed of 500 mm/sec) is 80 N. Performance Level: From the above, based on ISO 13849-1:2006:

S is S1, as possible operator collision forces will not injure operators.

F is F1 as normal operation does not involve collisions with robot.

P is P1 as the robot does not make unexpected motions.

So PL is “a”, and even a Category B controller is sufficient, given the low speeds and small possible collisions forces involved which cannot injure an operator. (See 5.2.3 under EN/ISO 10218-1:2011).

Appendix G: TUV Verification of PF400 Collision Forces



Technical Report No. 72112676-001
Rev. 0
Dated: January 18, 2016

Client: *Precise Automation*
 47350 Fremont Blvd., Fremont, CA 94538

Manufacturing place: Jabil Industries
 1565 S. Sinclair St., Anaheim, CA 92806

Test subject: Product: Collaborative Robot
 Type: PF400

Test specification: *Maximum applied forces testing*

Purpose of examination:

- Verification of operation as a Collaborative Robot when applied as instructed by Precise Automation using the provided and confirmed force data included in this report.

The Force data and Settings information are provided so that the end-user has sufficient information to perform a Risk Assessment and determine how the robot may safely be used in a Collaborative application. In the table below, green cells indicate crushing forces less than 150N for manual control and impact forces less than 180N for free space and rigid surface collisions. Red cells indicate collision forces greater than 180N. The operation of the Robot was verified for safe operation in selected single fault failures. However, the overall reliability of the control system per applicable standards was not verified.

Test result: *positive*: The test subject was found to be in compliance with

- the requirements of the test specification

This technical report may only be quoted in full. Any use for advertising purposes must be granted in writing. This report is the result of a single examination of the object in question and is not generally applicable evaluation of the quality of other products in regular production.

PSS_F_09.07 Revision 3, Effective: 2015-02-17
Page 1 of 4 ®

Figure 2-15: TUV Verification of PF400 Collision Forces, Page 1 of 4



1 Description of the test subject

1.1 Function

Manufacturer's specification for intended use:
According to the user manual

Manufacturer's specification for predictive misuse:
According to the user manual

1.2 Technical Data: Witnessed Force Testing as a Collaborative Robot

PF400 Test Data

160112

PF400 standard length

PAC Files PreciseFlex 400S Handler Prod_B40

Configuration	J1	J2	J3	J4	J5	Rail	XYZ
10351	9000	0	0	0	0	0	
10352	-4500	0	0	0	0	0	
Peak current, tcnts	32767	31491	32767	19450	4004	22933	
PID Error (10352) % of peak	14%	100%	100%	100%	100%	100%	
Standard Config for crash tests	131	-52	112	299	80	-230	
Config J2 Rotation (max velocity)	131	-27	53	335	80	NA	
100% Joint Speed	500mm/s	360 deg/s	720 deg/s	720 deg/s	400mm/s	750mm/s	
100% Joint Accel	3500	1500	2300	4000	10000	1000	
100% XYZ Speed							500
100% XYZ Accel							2500

PF400 Collisions at Gripper									Z decel		
Speed	Manual Control			Free Space Collision			Rigid Surface Collision			100%	40%
	X	Y	-Z	X	Y	-Z .5kg	X	Y	J2 rot	-Z .5kg	-Z .5kg
100%	62	20	60	31	52	75	98	97	163	206	153
80%	61	20	57	31	43	77	85	76	116	175	135
60%	62	19	58	23	31	92	72	64	97	144	114
40%	61	20	57	22	32	79	60	37	68	112	101
20%	61	19	57	22	30	73	50	22	33	94	86
10%	58	29	57	22	29	66	46	22	21	79	75

Figure 2-16: TUV Verification of PF400 Collision Forces, Page 2 of 4



Linear Rail Collisions at Z Column			
Speed	Manual	Free	Rigid
	X	X	X
100%	148	159	235
80%	149	162	205
60%	143	160	184
40%	141	168	177
20%	140	164	155
10%	140	157	150

2. Order

2.1 Date of Purchase Order, Customer's Reference

January 4, 2016

2.2 Receipt of Test Sample, Location

NA

2.3 Date of Testing and/or Evaluation

January 11 thru 12, 2016

2.4 Location of Testing and/or Evaluation

At Precise Automation, Fremont, CA

2.5 Points of Non-compliance or Exceptions of the Test Procedure and/or Evaluation procedure.

Positive

3. Test/Evaluation Results

3.1 Positive Test/Evaluation Results

- Operation safety during single failure
- Mechanical safety – Applied forces: Manual Control, Free Space Collision and Rigid Surface Collision

3.2 Points of non-compliance according to the test/evaluation specification

None

Figure 2-17: TUV Verification of PF400 Collision Forces, Page 3 of 4

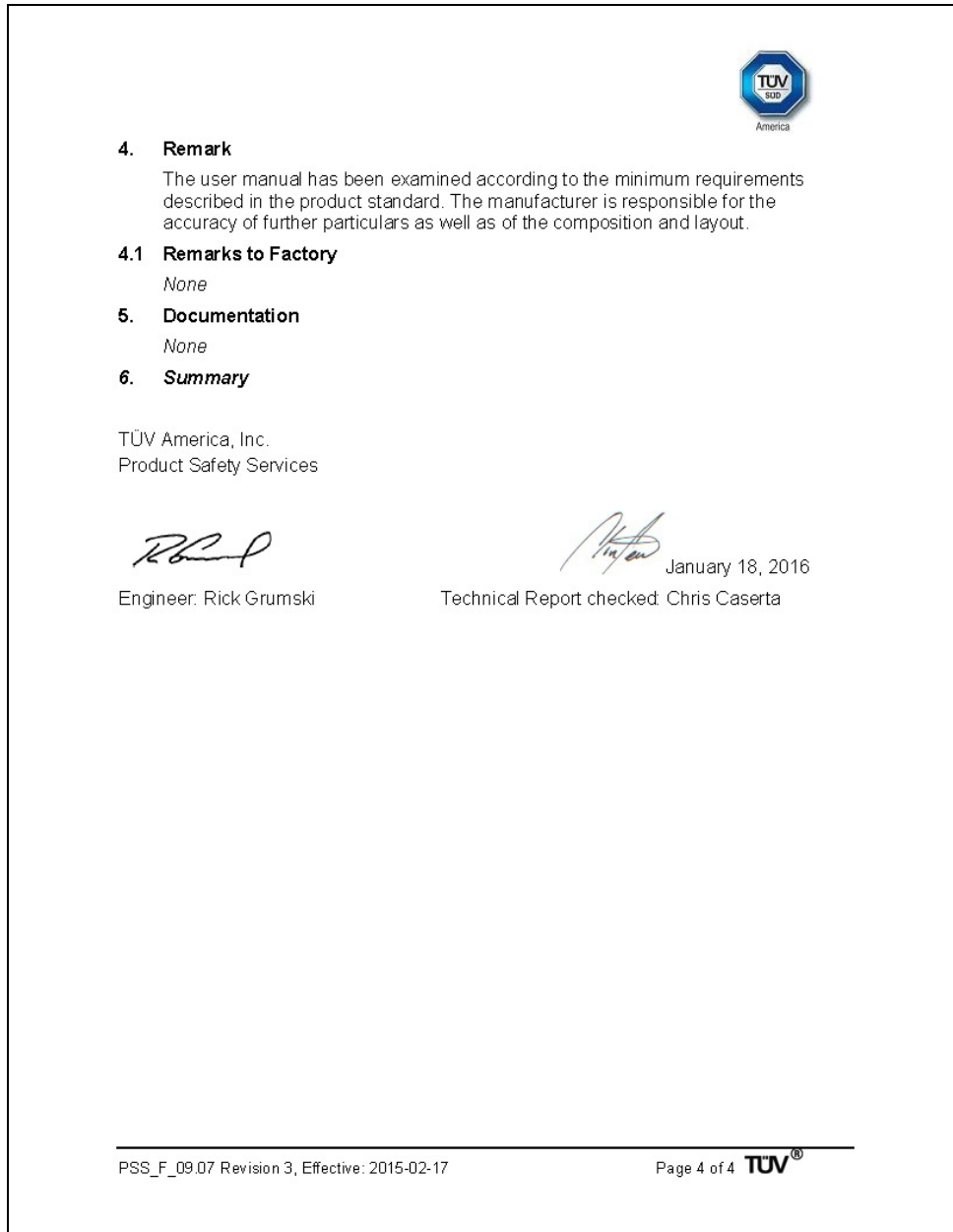

Figure 2-18: TUV Verification of PF400 Collision Forces, Page 4 of 4

Appendix H: Table A2 from ISO/TS 15066: 2016, Biomechanical Limits

Body region	Specific body area		Quasi-static contact		Transient contact	
			Maximum permissible pressure ^a p_s N/cm ²	Maximum permissible force ^b N	Maximum permissible pressure multiplier ^c P_T	Maximum permissible force multiplier ^c F_T
<i>Skull and forehead^d</i>	1	<i>Middle of forehead</i>	130	130	not applicable	not applicable
	2	<i>Temple</i>	110		not applicable	
<i>Face^d</i>	3	<i>Masticatory muscle</i>	110	65	not applicable	not applicable
Neck	4	Neck muscle	140	150	2	2
	5	Seventh neck muscle	210		2	
Back and shoulders	6	Shoulder joint	160	210	2	2
	7	Fifth lumbar vertebra	210		2	
Chest	8	Sternum	120	140	2	2
	9	Pectoral muscle	170		2	
Abdomen	10	Abdominal muscle	140	110	2	2
Pelvis	11	Pelvic bone	210	180	2	2
Upper arms and elbow joints	12	Deltoid muscle	190	150	2	2
	13	Humerus	220		2	
Lower arms and wrist joints	14	Radial bone	190	160	2	2
	15	Forearm muscle	180		2	
	16	Arm nerve	180		2	

^a These biomechanical values are the result of the study conducted by the University of Mainz on pain onset levels. Although this research was performed using state-of-the-art testing techniques, the values shown here are the result of a single study in a subject area that has not been the basis of extensive research. There is anticipation that additional studies will be conducted in the future that could result in modification of these values. Testing was conducted using 100 healthy adult test subjects on 29 specific body areas, and for each of the body areas, pressure and force limits for quasi-static contact were established evaluating onset of pain thresholds. The maximum permissible pressure values shown here represent the 75th percentile of the range of recorded values for a specific body area. They are defined as the physical quantity corresponding to when pressures applied to the specific body area create a sensation corresponding to the onset of pain. Peak pressures are based on averages with a resolution size of 1 mm². The study results are based on a test apparatus using a flat (1.4 × 1.4) cm (metal) test surface with 2 mm radius on all four edges. There is a possibility that another test apparatus could yield different results. For more details of the study, see Reference [5].

^b The values for maximum permissible force have been derived from a study carried out by an independent organization (see Reference [6]), referring to 188 sources. These values refer only to the body regions, not to the more specific areas. The maximum permissible force is based on the lowest energy transfer criteria that could result in a minor injury, such as a bruise, equivalent to a severity of 1 on the Abbreviated Injury Scale (AIS) established by the Association for the Advancement of Automotive Medicine. Adherence to the limits will prevent the occurrence of skin or soft tissue penetrations that are accompanied by bloody wounds, fractures or other skeletal damage and to be below AIS 1. They will be replaced in future by values from a research more specific for collaborative robots.

^c The multiplier value for transient contact has been derived based on studies which show that transient limit values can be at least twice as great as quasi-static values for force and pressure. For study details, see References [2], [3], [4] and [7].

^d Critical zone (*italicized*)

Figure 2-19: Biomechanical Limits, Page 1 of 2

Body region	Specific body area		Quasi-static contact		Transient contact	
			Maximum permissible pressure ^a p_s N/cm ²	Maximum permissible force ^b N	Maximum permissible pressure multiplier ^c P_T	Maximum permissible force multiplier ^c F_T
Hands and fingers	17	Forefinger pad D	300	140	2	2
	18	Forefinger pad ND	270		2	
	19	Forefinger end joint D	280		2	
	20	Forefinger end joint ND	220		2	
	21	Thenar eminence	200		2	
	22	Palm D	260		2	
	23	Palm ND	260		2	
	24	Back of the hand D	200		2	
	25	Back of the hand ND	190		2	
Thighs and knees	26	Thigh muscle	250	220	2	2
	27	Kneecap	220		2	
Lower legs	28	Middle of shin	220	130	2	2
	29	Calf muscle	210		2	

^a These biomechanical values are the result of the study conducted by the University of Mainz on pain onset levels. Although this research was performed using state-of-the-art testing techniques, the values shown here are the result of a single study in a subject area that has not been the basis of extensive research. There is anticipation that additional studies will be conducted in the future that could result in modification of these values. Testing was conducted using 100 healthy adult test subjects on 29 specific body areas, and for each of the body areas, pressure and force limits for quasi-static contact were established evaluating onset of pain thresholds. The maximum permissible pressure values shown here represent the 75th percentile of the range of recorded values for a specific body area. They are defined as the physical quantity corresponding to when pressures applied to the specific body area create a sensation corresponding to the onset of pain. Peak pressures are based on averages with a resolution size of 1 mm². The study results are based on a test apparatus using a flat (1,4 × 1,4) cm (metal) test surface with 2 mm radius on all four edges. There is a possibility that another test apparatus could yield different results. For more details of the study, see Reference [5].

^b The values for maximum permissible force have been derived from a study carried out by an independent organization (see Reference [6]), referring to 188 sources. These values refer only to the body regions, not to the more specific areas. The maximum permissible force is based on the lowest energy transfer criteria that could result in a minor injury, such as a bruise, equivalent to a severity of 1 on the Abbreviated Injury Scale (AIS) established by the Association for the Advancement of Automotive Medicine. Adherence to the limits will prevent the occurrence of skin or soft tissue penetrations that are accompanied by bloody wounds, fractures or other skeletal damage and to be below AIS 1. They will be replaced in future by values from a research more specific for collaborative robots.

^c The multiplier value for transient contact has been derived based on studies which show that transient limit values can be at least twice as great as quasi-static values for force and pressure. For study details, see References [2], [3], [4] and [7].

^d Critical zone (*italicized*)

Figure 2-20: Biomechanical Limits, Page 2 of 2

Appendix I: Safety Circuits for PF400 500gm Payload

14-Jun-17	PF400 500gm								
Safety Circuit	Start up Test	Redundant	Continuous Test	Diagnostic Coverage	MTTF, Years	Power Off/On Failure	PL	Category Safety	Notes
Estop	No	Yes	No	50%	92	Yes	c	1	Estop turns off amp enable and PWM Stopping robot with hand turns off amp enable and PWM to amp
Encoder Feedback	Yes	No	Yes	90%	58	Yes	d	3	Startup test checks encoder communication, prevents mtr power if fault Serial update at 8Khz w checksum, comm check, accel check Counter embedded in position word to confirm CPU read from FPGA
CPU Monitor	No	No	Yes	99%	100	Yes	d	1	FPGA watchdog timer turns off amp enable and PWM
Position Envelope Error	Yes	Yes	Yes	90%	57	Yes	d	3	Startup test checks encoder communication, prevents mtr power if fault Serial update at 8Khz w checksum, comm check, accel check SW watchdog in servo loop turns off amp enable, PWM and 48V Counter embedded in position word to confirm CPU read from FPGA
Power amp Fault	Yes	Yes	Yes	90%	100	Yes	d	3	Startup test confirms zero current when 48V enabled Excess current to ground or phase to phase triggers shutdown in 10 usec Saturated PID current command triggers shutdown in .050sec Shorted transistor just locks up brushless motor
Collab Force Limit	Yes	Yes	Yes	90%	SW	Yes	d	3	Tests 2, 3, 4 above test HW. Motor driven against brake to test SW current Current saturation triggers separate fault, turns off amp enable and PWM Monitor function with WD turns off amp enable and PWM to amp Assymetric current limits limit Z force even with gravity load
Velocity Restrict	Yes	Yes	Yes	99%	93	Yes	d	3	Startup test, sets flag to trigger this error, then resets Checks velocity limit in FPGA in addition to check in CPU servo software
									1. Cat 2 and Cat 3 require startup test before enabling motor power

Figure 2-21: Safety Circuits for PF400 500gm Payload

Appendix J: Robot Anatomy

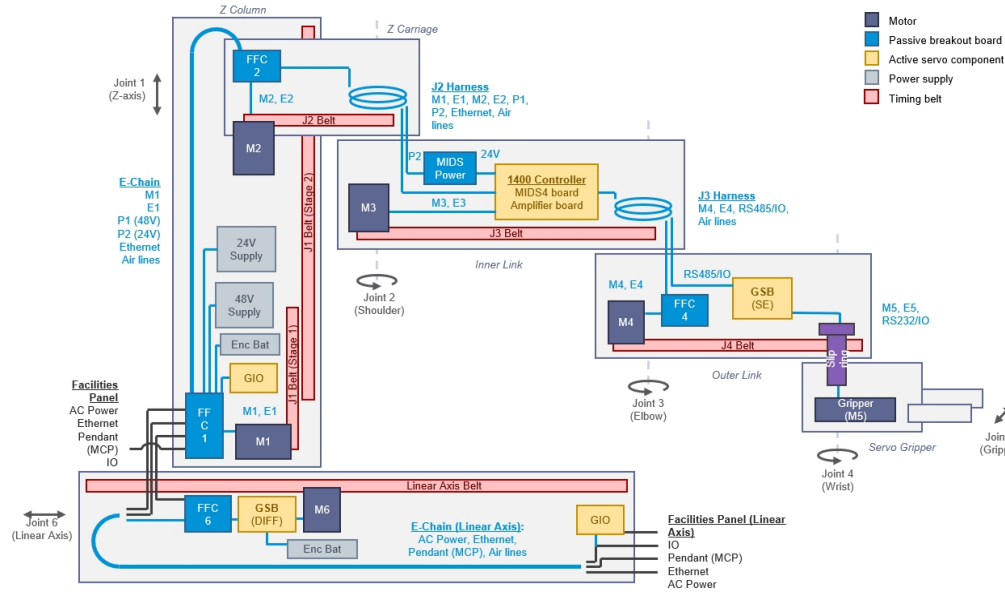

Four Axes - with Rail

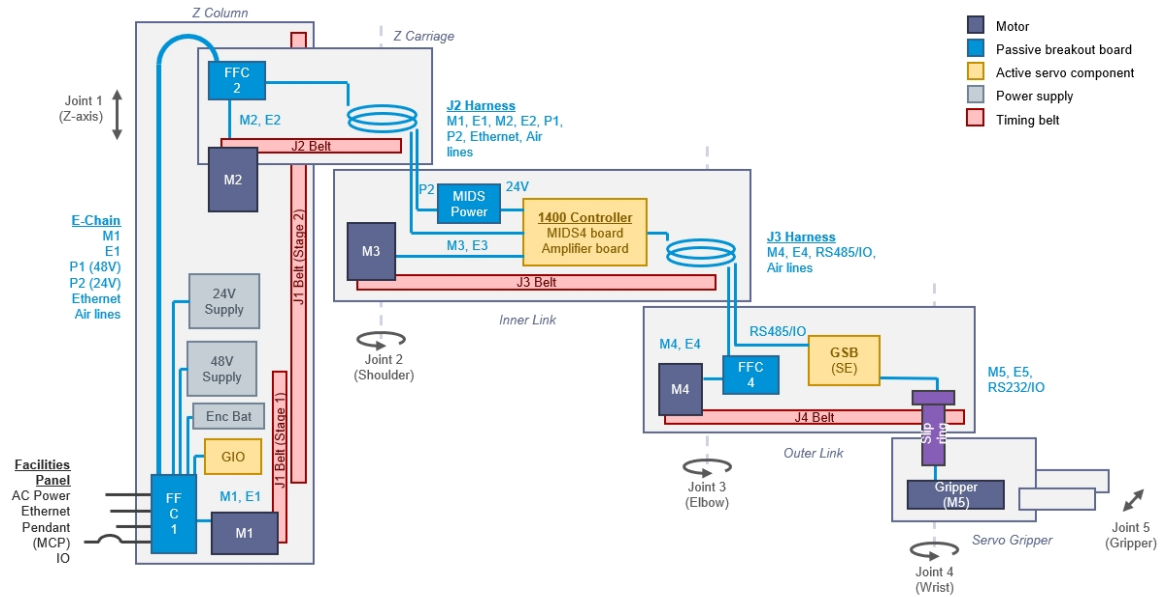

Four Axes - No Rail

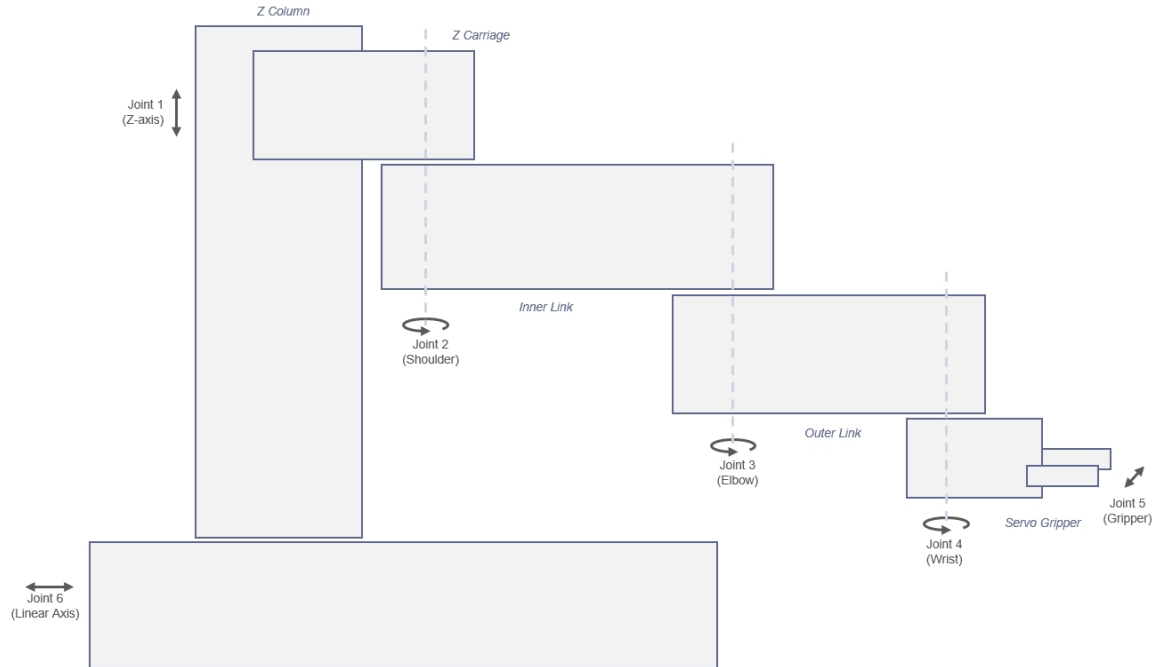

Four Axes – Joints

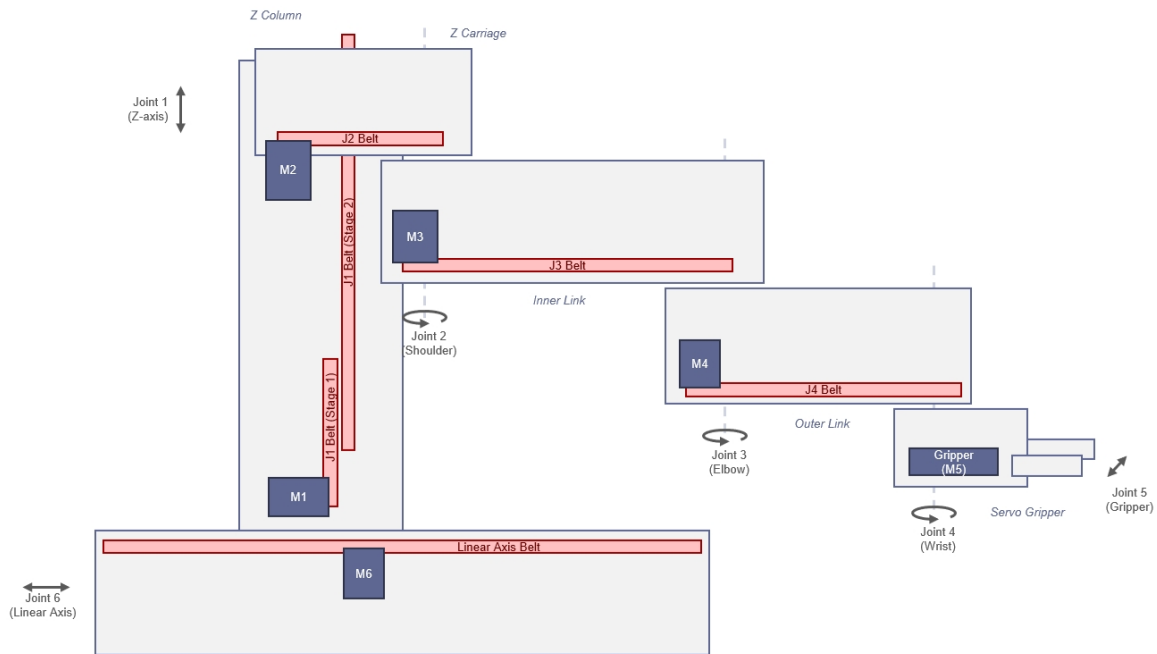

Four Axes – Belt Drives

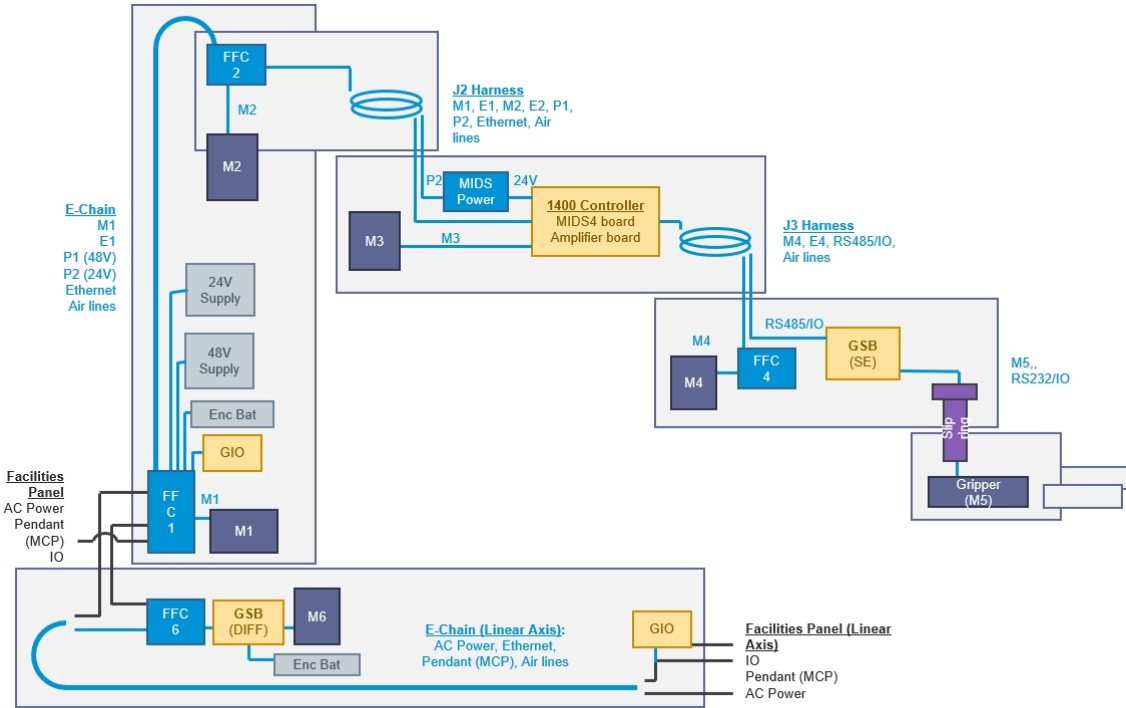

Four Axes – Power

Appendix K: System Diagram and Power Supplies

The robot has a 24 VDC and 48 VDC power supply located in the Z column. For Revisions A and B, the AC input to these power supplies is fused with two fuses in a pull-out fuse drawer in the IEC type power entry module. For Revision C and later, these fuses have been removed. The power supplies have both over-current and over-voltage protection and are CSA, UL, and CE certified.

The robot controller and electric gripper are powered by the 24 VDC supply. The four main robot motors are powered by the 48 VDC supply. The 48 VDC supply is protected against over-voltage bus pump up by an energy dump circuit, which connects a 25-Watt dump resistor across the 48 VDC supply output when the voltage reaches 56 Volts and disconnects the dump resistor when the voltage drops to 52 Volts. This protects the power supply during high speed motor deceleration when the motor generates Back EMF voltage that adds to the power supply voltage.

DC power is routed from the power supplies to an interconnect board in the base of the Z column (Z Base Motor Interface Board). From this interconnect board, the power is routed in P1 and P2 flat ribbon cables. The P2 cable contains the 48 VDC motor power and is connected to the power amplifier board in the controller. The P1 cable contains the 24 VDC controller power and is routed to a second interconnect board (the MIDS Power Interface Board), which is mounted on the side wall inside the inner link of the robot. From this board, 24 VDC power is connected to the main robot controller.

Four digital input and four digital output signals from the main robot controller are also connected to the MIDS Power Interface Board through a ten-conductor ribbon cable. One digital input signal, DI3, is routed down to the base of the robot thru the P1 ribbon cable where it is connected to the green Phoenix E-Stop connector. This provides a digital input for safety interlock purposes. There is a jumper on the MIDS Power Board which jumps this signal to the P1 cable. This jumper must be installed for this connection to work.

The rest of the digital inputs and outputs are daisy chained to a second connector on the MIDS board for use if needed. Some of these signals are used when the pneumatic gripper option is installed.

The E-Stop circuit is also connected from the controller to MIDS Power Interface Board and down through the P1 cable to two E-Stop connectors: the green Phoenix connector (J24) and the 9 pin Dsub connector (J30). The E-Stop pins on these connectors are wired in series so that both connectors must have either a jumper or E-Stop switch installed that completes the E-Stop circuit.

The gripper controller is connected to the main controller through an RS-485 cable routed through the elbow along with the power and encoder cables for the J4 motor. The RS-485 cable also supplies power for the gripper controller.

The motors for the Z column, the shoulder, and the wrist all plug into an interconnect board that converts the signals from the motor cables to the flat ribbon cables. The motor for the elbow plugs directly into the controller amplifier board in the inner link.

The cable from the brake release button under the shoulder plugs into the amplifier board in the inner link. This button provides a ground return from the Z column brake to ground bypassing the transistor that performs this function under computer power so that the brake can be released manually without motor power being enabled.

[Figure 2-22](#) through [Figure 2-40](#) show the schematics.

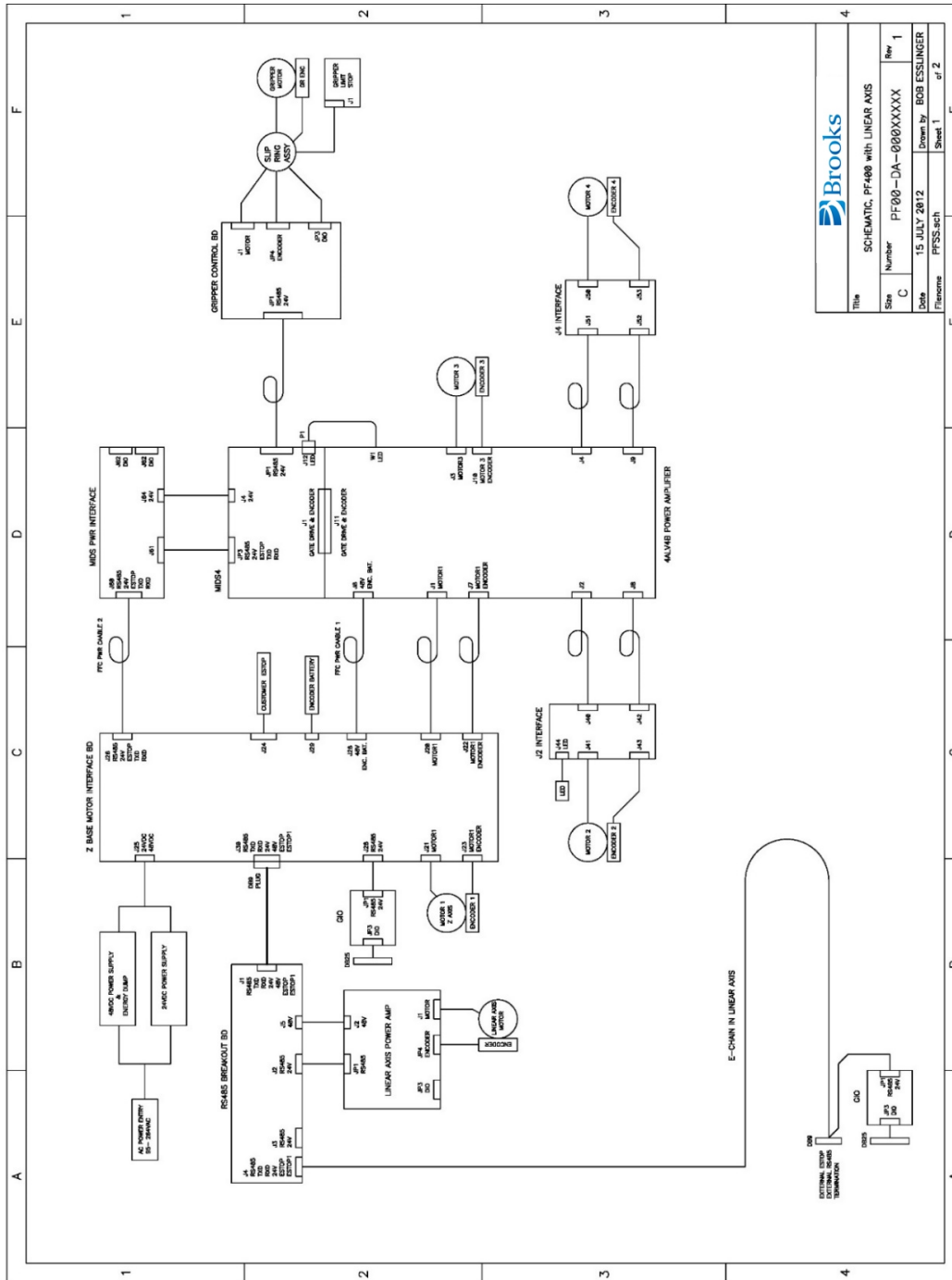

Figure 2-22: System Overview, PF400 with Linear Axis

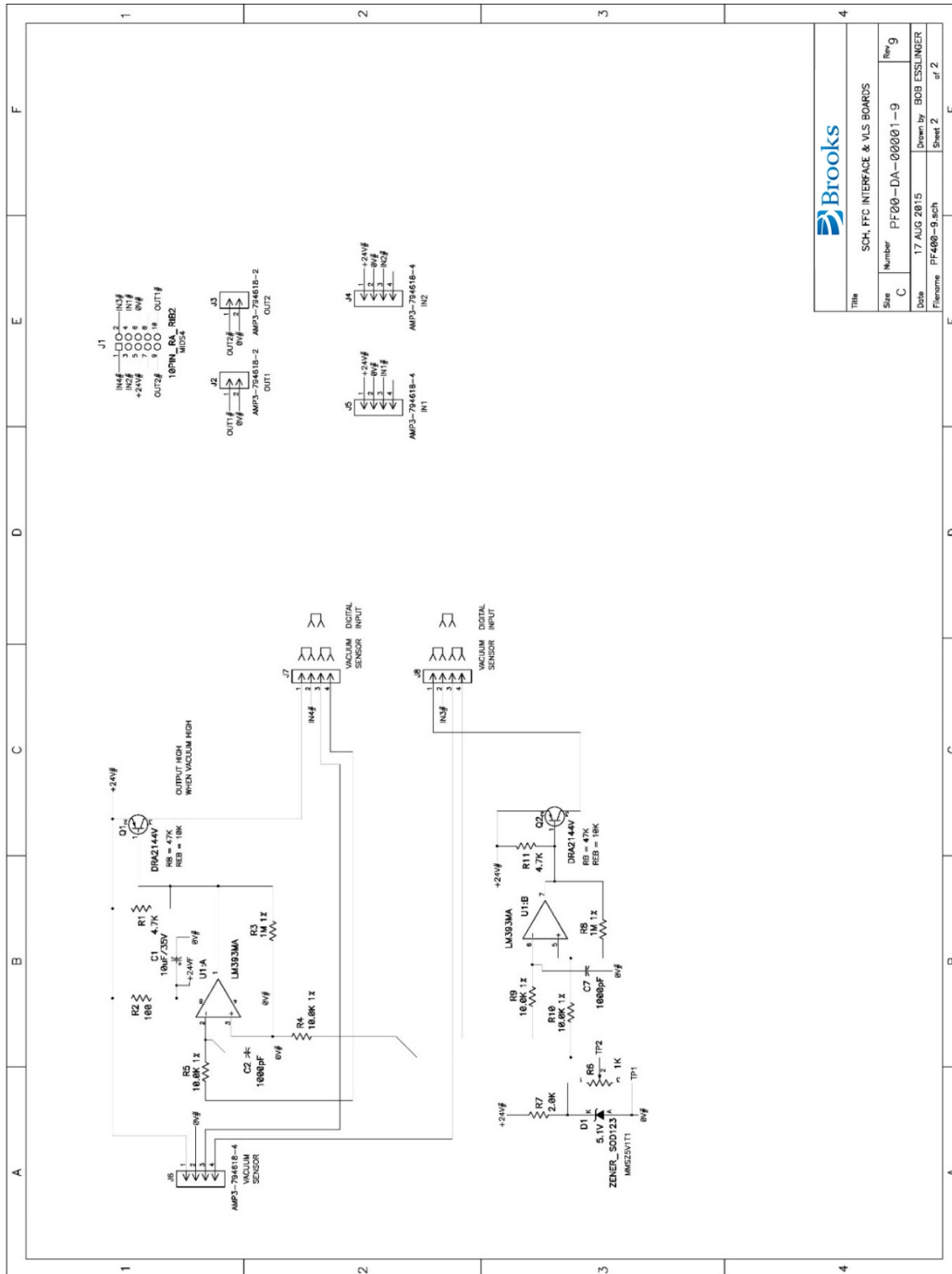

Figure 2-23: FFC Boards Revision B, PF400, SCH, FFC Interface & VLS Boards

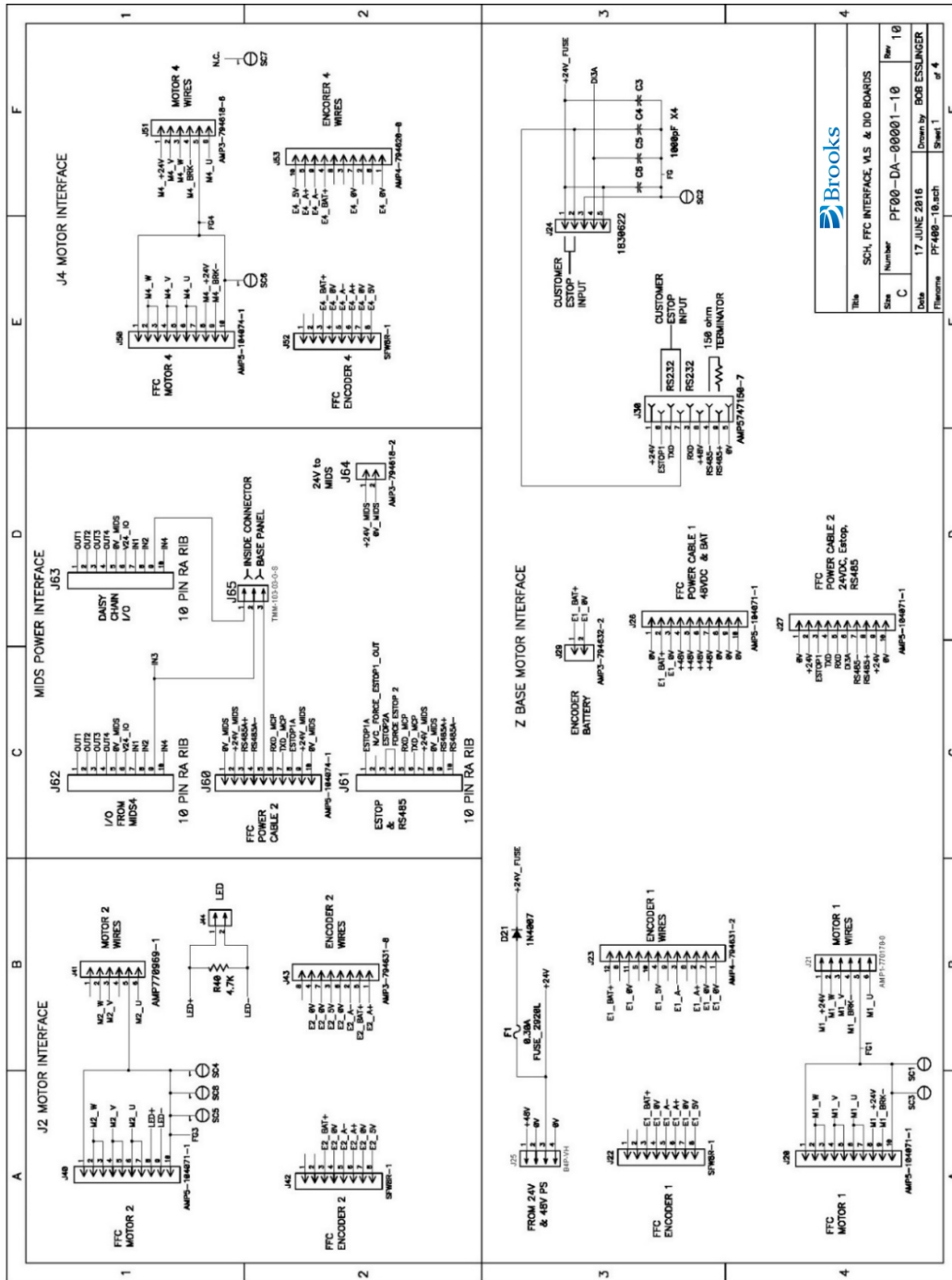

Figure 2-24: SCH, FFC Interface, VLS & DIO Boards

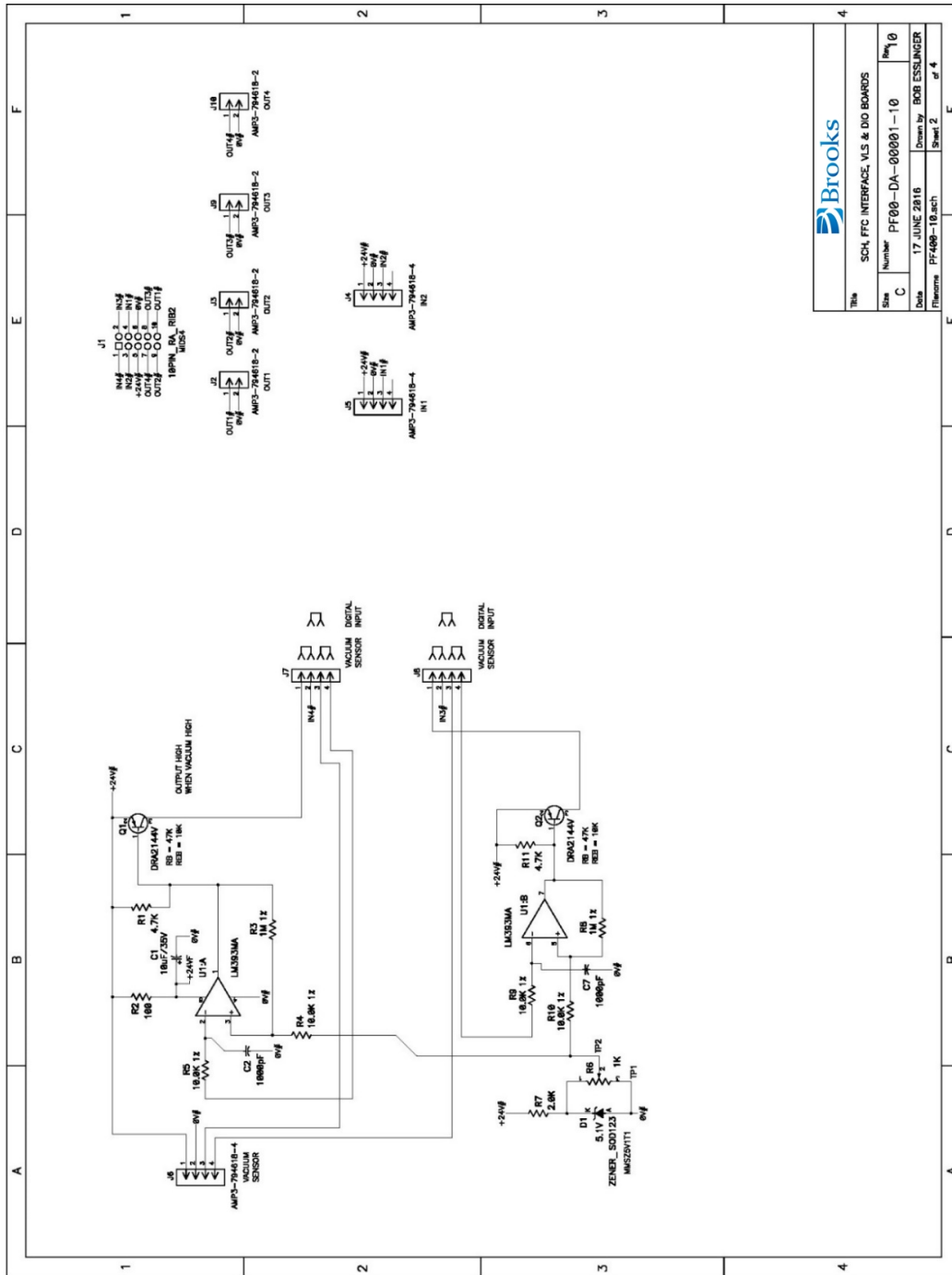

Figure 2-25: FFC Boards Revision C PF400, SCH, FLC Interface, VLS & DIO Boards

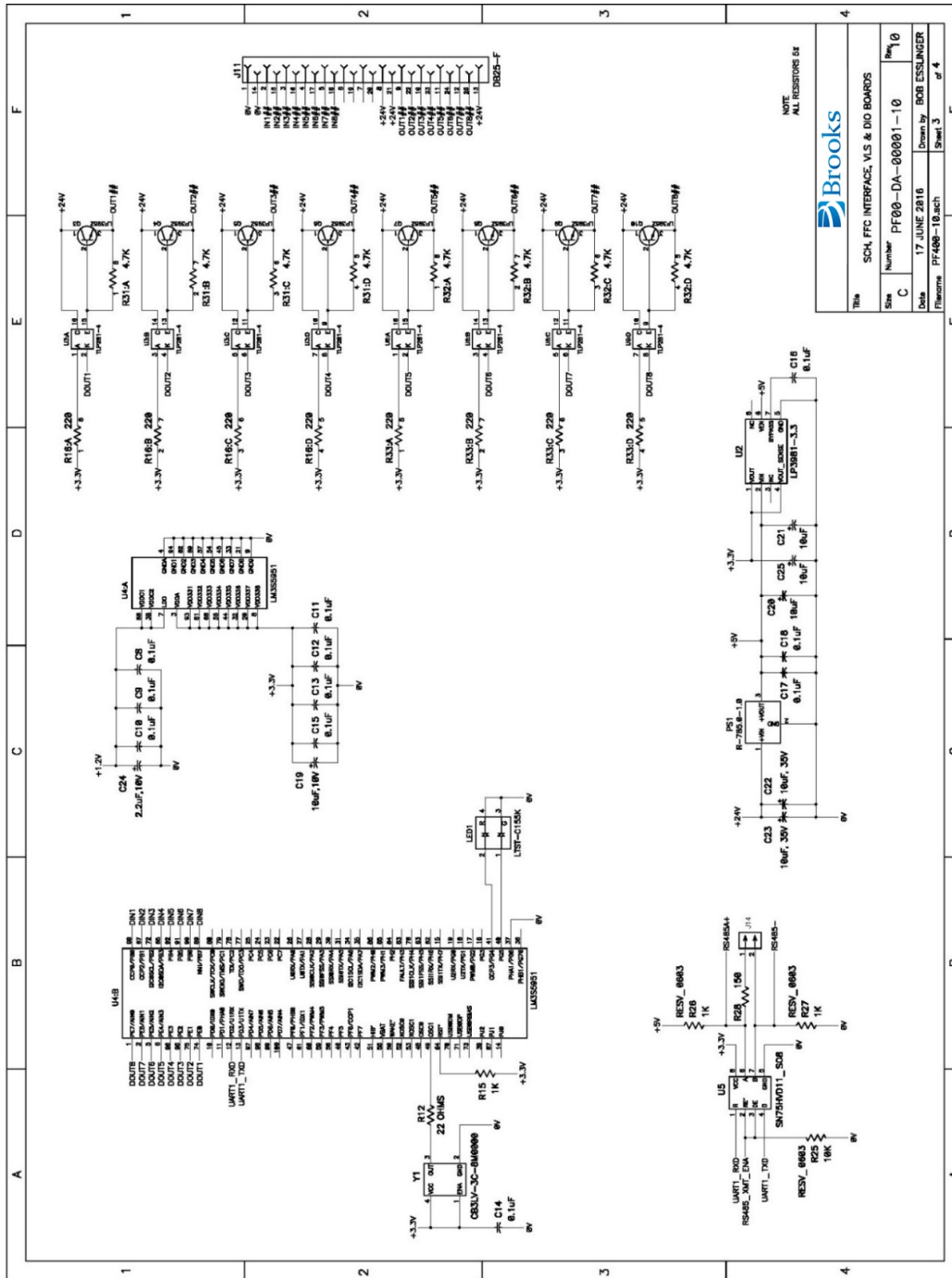

Figure 2-26: SCH, FFC Interface, VLS & DIO Boards

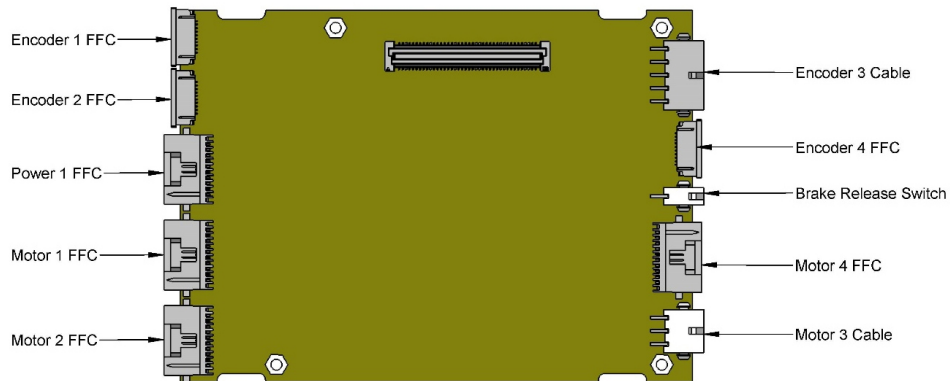

Figure 2-28: Controller Power Amplifier Connectors

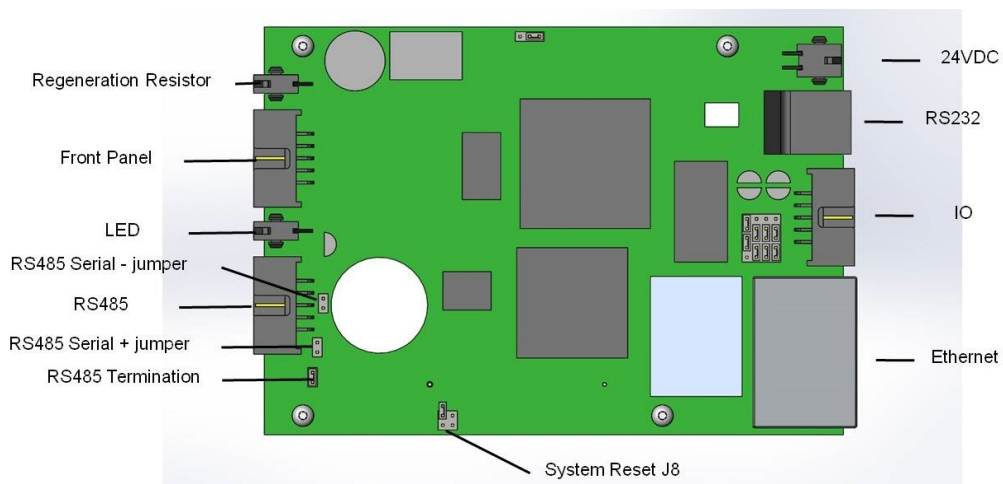

Figure 2-29: Controller Board Connectors

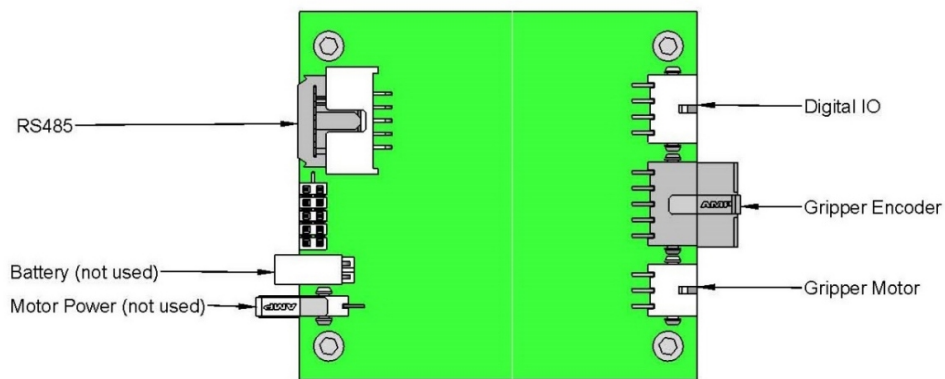

Figure 2-30: Gripper and Linear Axis Controller Connectors

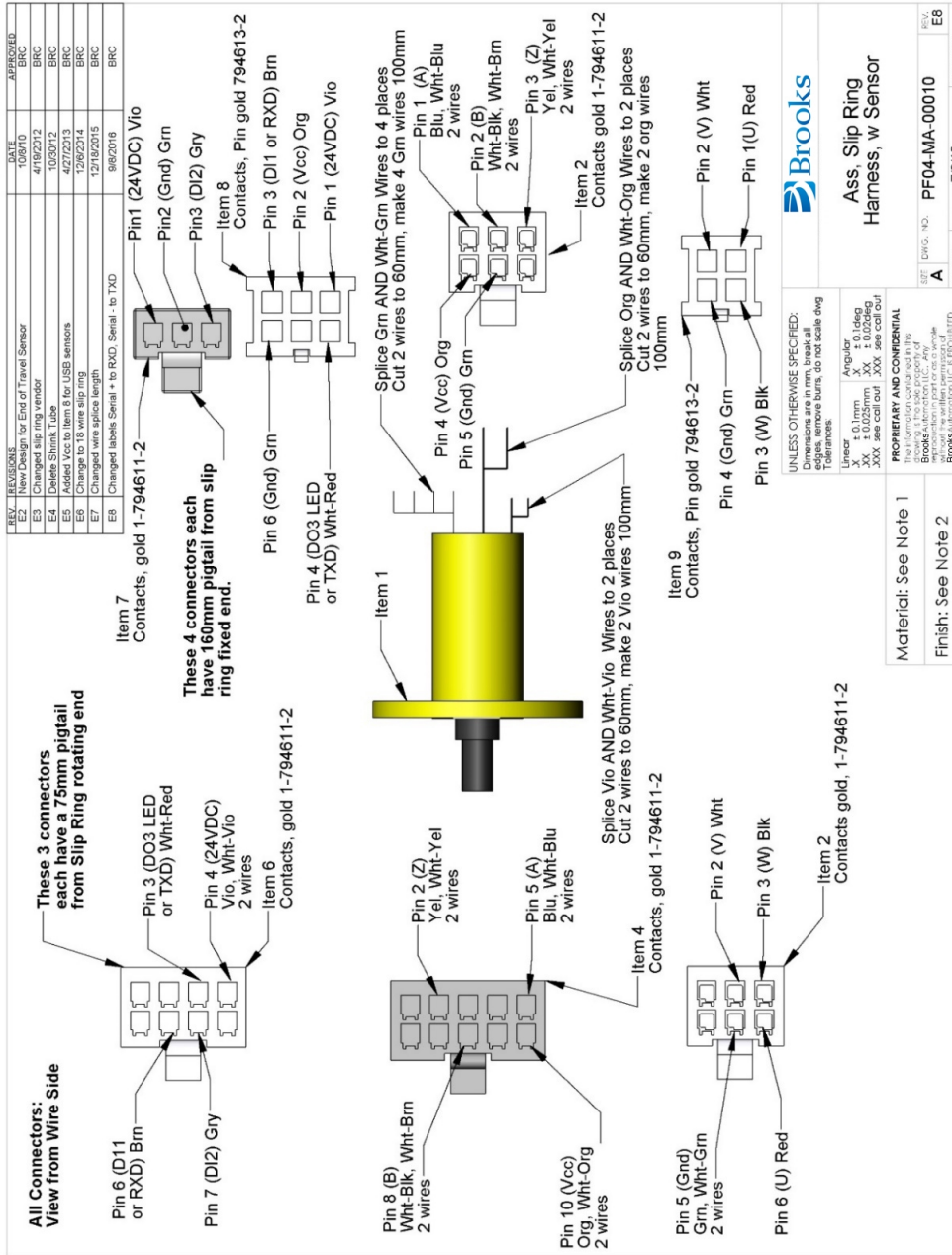

Figure 2-32: Assembly, Slip Ring Harness with Sensor

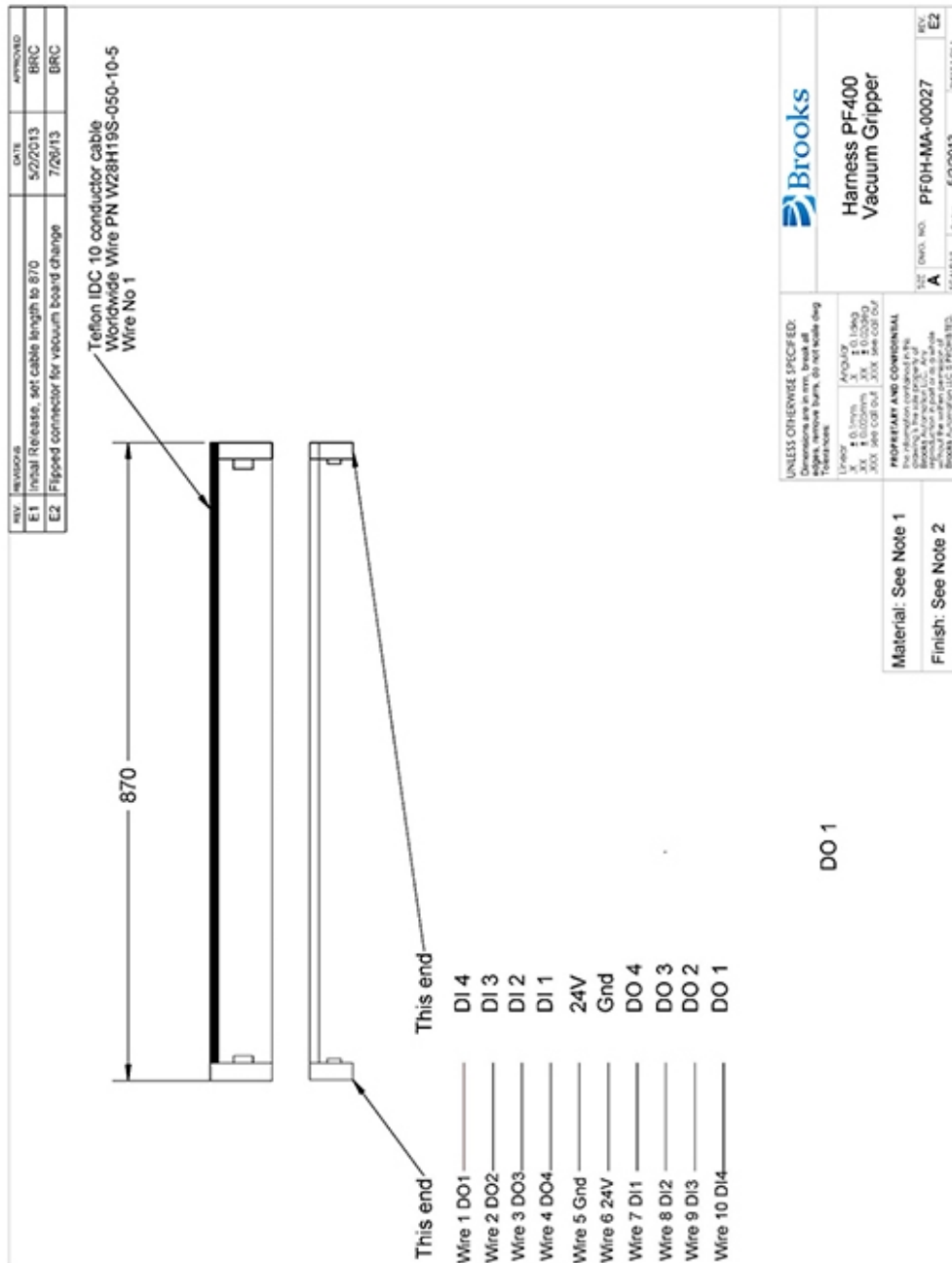

Figure 2-33: Harness PF400 Vacuum Gripper

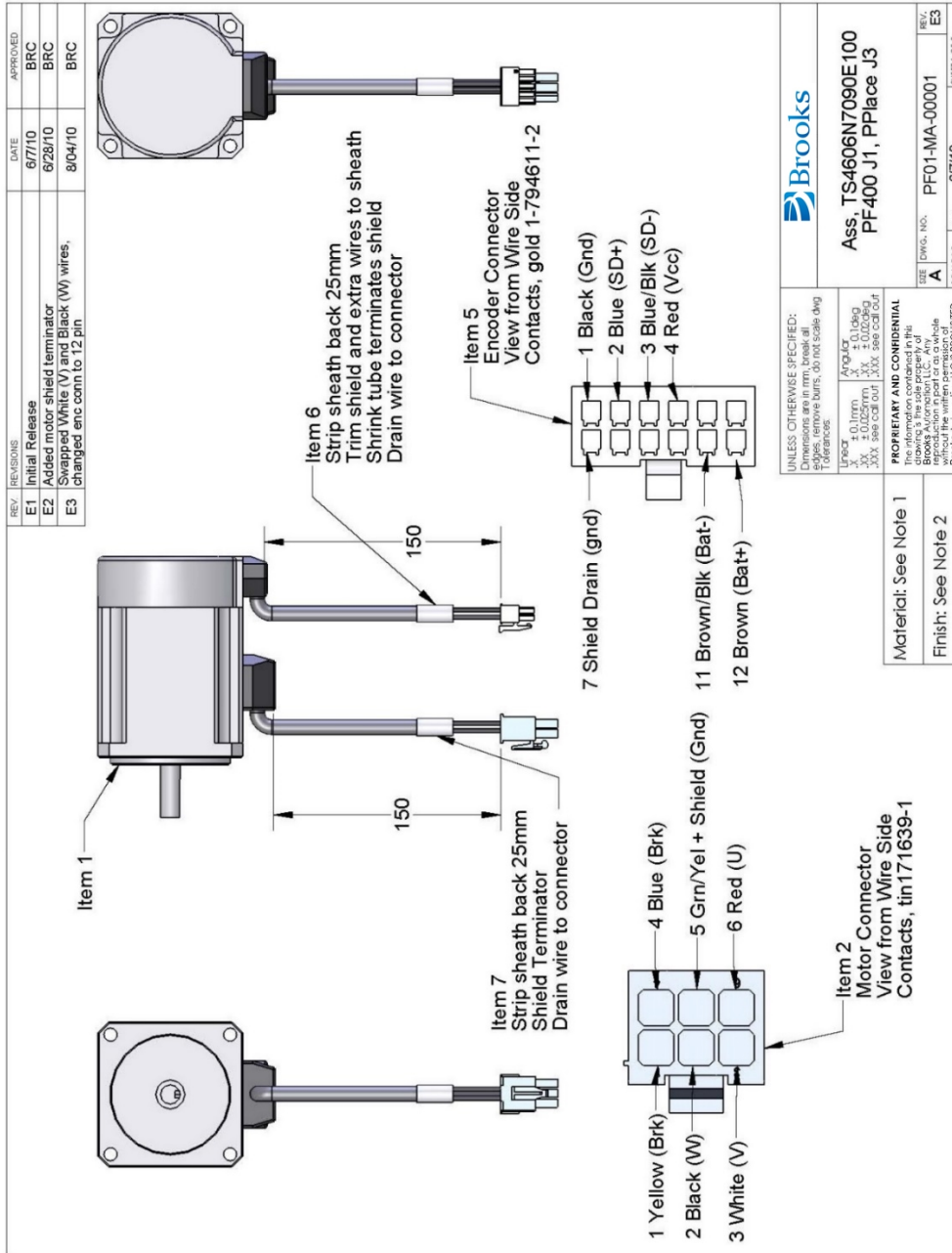

Figure 2-34: Assembly, TS4606N7090E 100, PF400 J1, PPlace J3

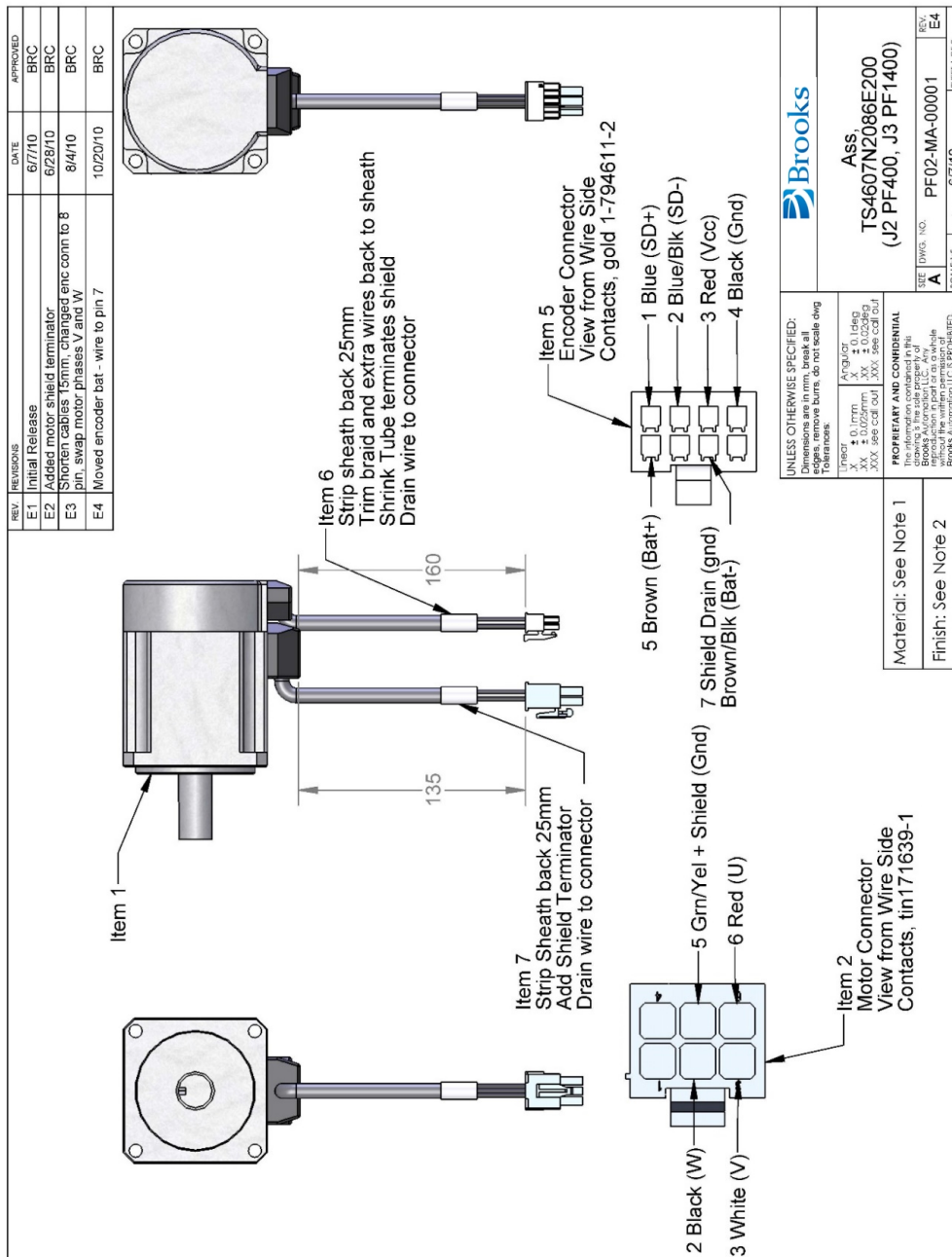

Figure 2-35: Assembly, TS4607N2086E200 (J2 PF400, J3 PF1400)

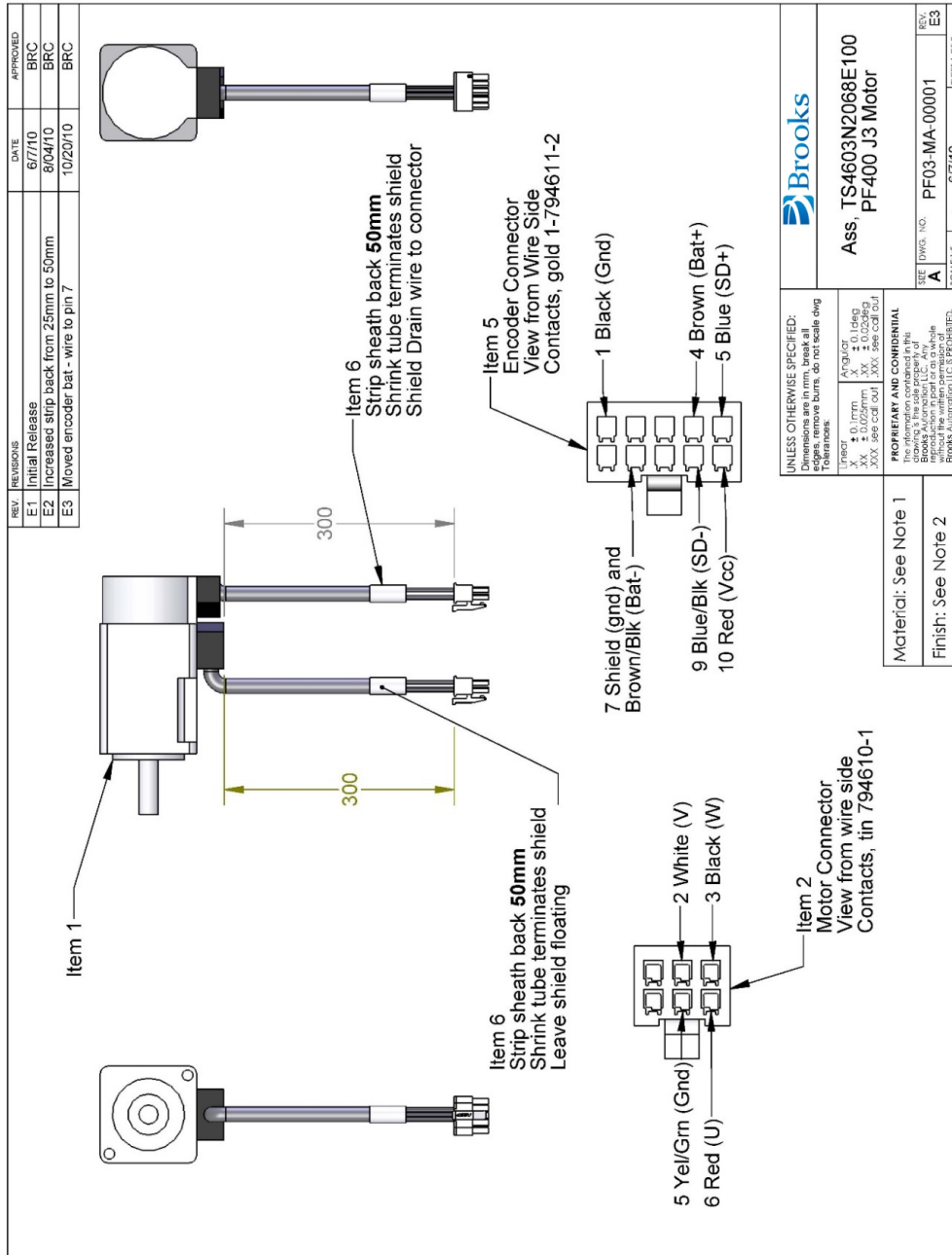

Figure 2-36: Assembly, TS4603N2068E100 PF400 J3 Motor

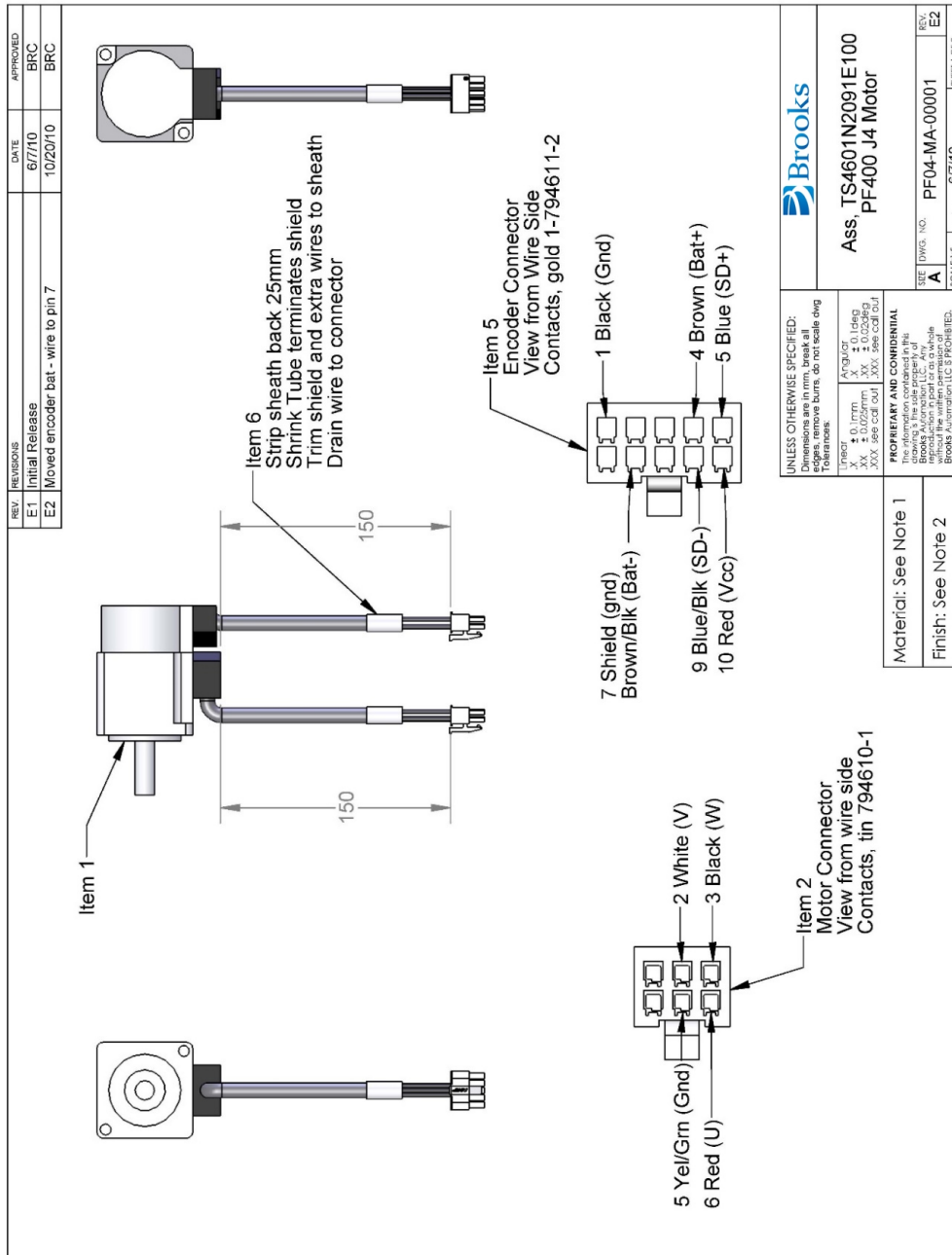

Figure 2-37: Assembly, TS4601N2091E100 PF400 J4 Motor

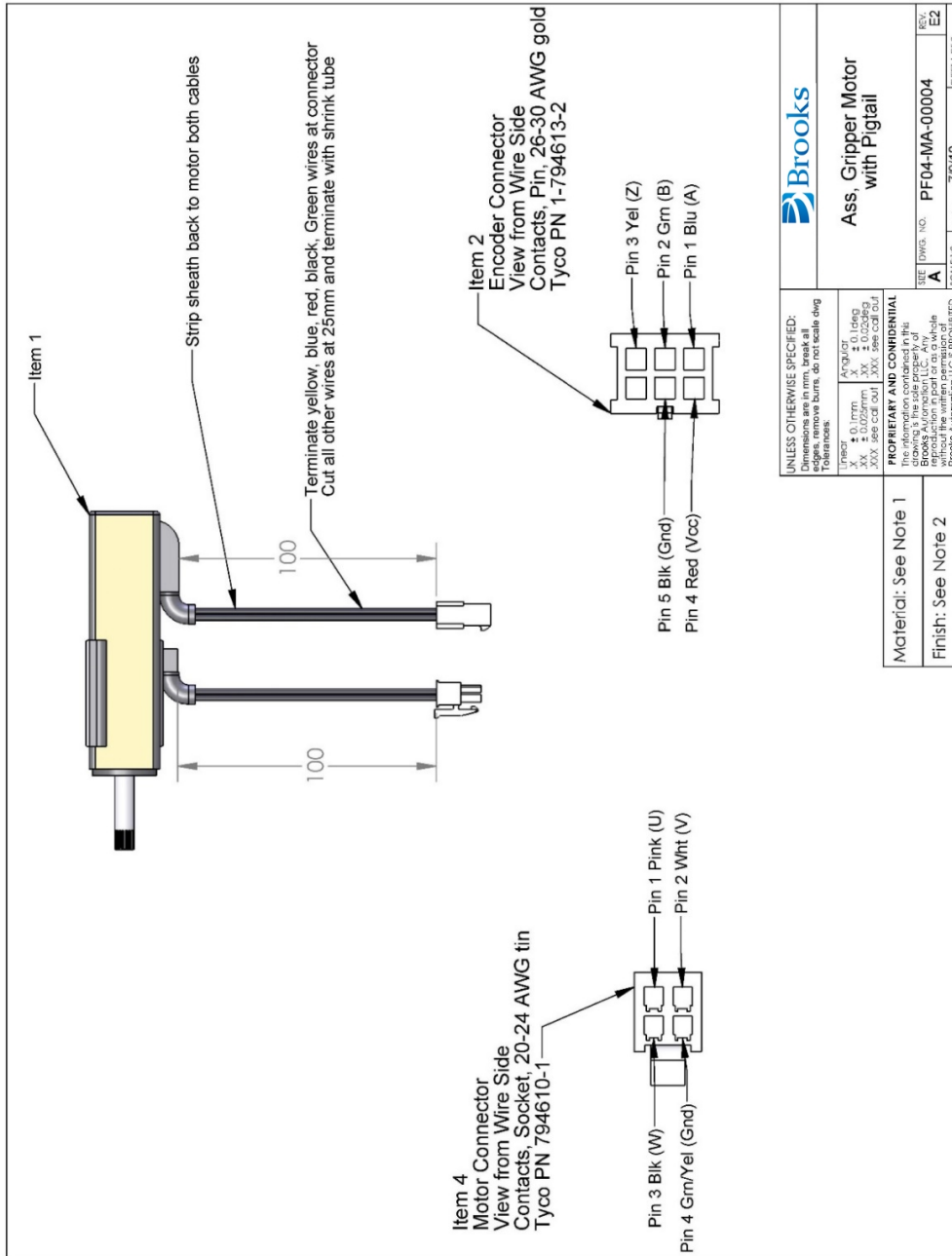

Figure 2-38: Assembly, Gripper Motor with Pigtail

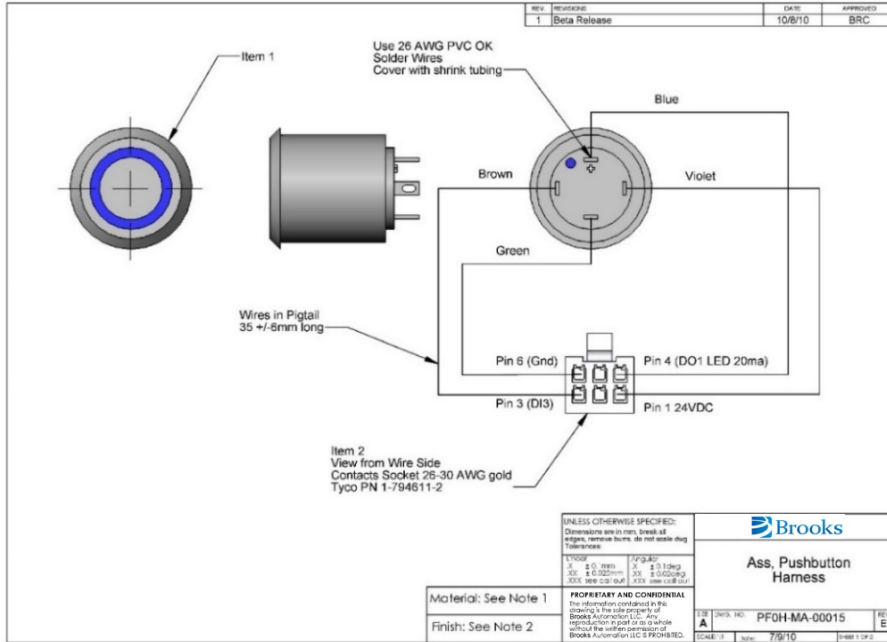

Figure 2-39: Assembly, Pushbutton Harness

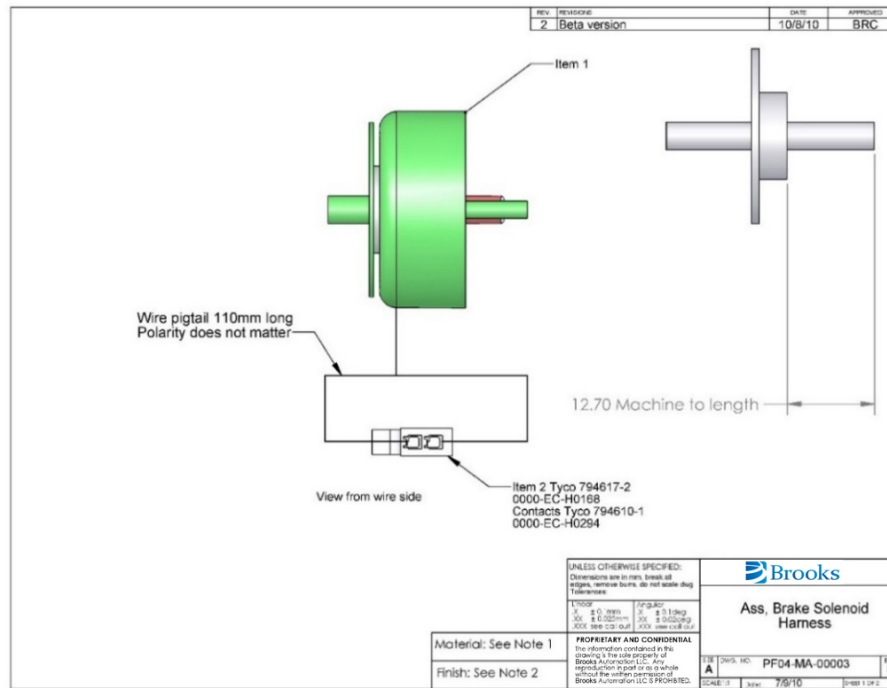

Figure 2-40: Assembly, Brake Solenoid Harness

Appendix L: Torque Values for Screws

Use these torque values for all screws and fasteners unless otherwise stated.

Torque Values in Newton-Meters

Screw Size M	Zinc	SS	Zinc	SS	Zinc	SS
	SHCS	SHCS	BHCS	BHCS	FHCS	FHCS
1.6	0.18	0.15	0.00	0.00	0.00	0.00
2	0.37	0.31	0.00	0.00	0.00	0.00
2.5	0.77	0.64	0.00	0.00	0.00	0.00
3	1.34	1.12	0.56	0.51	0.83	0.75
4	3.16	2.63	1.31	1.17	1.53	1.38
5	6.48	5.40	2.66	2.39	3.11	2.79
6	10.96	9.14	4.50	4.05	5.40	4.86